

SP30-25-15HBG2, SP30-25-15HBPS

Hybrid Energy Storage Converter

User Manual



Version: V1.3

Date of publication: 26 December 2024

Catalogue

1	Manual	4
1.1	Applicable products	4
1.2	Applicable personnel	4
1.3	symbol definition	4
2	Security	4
2.1	General Description	5
2.2	stringing safety.....	5
2.3	hybrid converter safety	5
2.4	Battery safety	7
2.5	Personnel Requirements	7
2.6	handling safety.....	7
3	product presentation.....	7
3.1	product features	7
3.1.1	product orientation	7
3.1.2	product superiority	8
3.1.3	Specification parameters	9
3.1.4	product work characteristic curve	13
3.1.5	The differences among the four models are explained as follows.....	15
3.2	Classic Product Applications	15
3.2.1	industrial and commercial energy storage.....	16
3.2.2	Off-grid Microgrid Solution.....	17
3.2.3	Three-phase unbalance and low voltage management	17
3.2.4	Energy Storage + Emergency Backup Power.....	18
3.2.5	multi-unit parallel scheme	18
3.3	Model name rules	19
3.4	Product Circuit Introduction	20
3.4.1	Introduction to Power Circuits	20
3.4.2	Work Mode Introduction	20
3.5	product mix.....	21
3.5.1	product appearance.....	21
3.5.2	product appearance.....	22
4	Transportation, storage, and installation	23
4.1	Transportation and storage.....	23

4.2	Unboxing and inspection	24
4.3	handling and installation.....	25
4.3.1	Installation and Handling Precautions.....	25
4.3.2	replacement tool	25
4.3.3	Installation environment.....	25
4.3.4	air duct requirements	28
5	Cable Connection Instructions	29
5.1	Port definition	29
5.2	cable wiring tool	32
5.3	DC side wiring.....	33
5.4	AC side wiring.....	34
5.5	Setting earth fault alarms notification.....	35
5.6	Wiring diagram.....	36
5.6.1	Cluster and Single Machine Connection Diagram	36
5.6.2	One cluster, one management, multiple machines in parallel (off-grid) ..	37
5.6.3	One cluster, one management, multiple machines in parallel (with off-grid switching capability)	38
5.6.4	Schematic diagram of multi-unit parallel connection of single battery pack (off-grid) 41	
5.6.5	Schematic diagram of multi-unit parallel connection with single battery pack (including grid connection/disconnection switching).....	42
6	Operation of Up and Down Power and Fault Diagnosis	45
6.1	Power on/off operation	45
6.1.1	Power-up procedure after initial power-up and maintenance	45
6.1.2	Preparation for the lower power step.....	52
6.1.3	boot up by host computer control.....	55
6.1.4	Customer EMS Control Operation and Power On/Off.....	56
6.1.5	Equipped with SAEMS100/SAEMS200 for control operation and power switching 56	
6.1.6	Contains information for setting up Generation Limit and ExportLimit Control 56	
6.2	fault diagnosis and solution	56
6.2.1	Module Alarm or Failure and Solutions	56

6.2.2	Battery Failure and Solutions	57
6.2.3	Power Grid Failure and Solutions	58
6.2.4	System Faults and Solutions of Module	60
7	Installation and Use of Host Computer	61
7.1	Installation and Uninstallation of Host Computer	61
7.2	Host computer usage.....	62
7.3	Host upgrade function.....	65
7.3.1	ARM native upgrade	65
7.3.2	DSP local upgrade	65
7.4	History and Faults.....	66
7.4.1	history.....	66
7.4.2	fault data.....	66
8	Other Notes	67
8.1	Temperature sensor interface	67
8.2	RCDs information.....	67
8.3	Nameplate Description	67
8.4	Active anti-islanding method.....	67
8.5	Warranty Terms and Conditions	68
8.6	Australia Region settings and modes response settings.....	68

1 Manual

This manual provides comprehensive guidance on hybrid converter product specifications, installation procedures, configuration and testing, troubleshooting, and maintenance. Before installation or use, please thoroughly review this manual to understand safety protocols and familiarize yourself with the product's features. Please note that the document may be updated periodically. For the latest version and additional product information, visit the official website.

1.1 Applicable products

This document applies to the following converter models:



SP30HBG2、SP25HBG2、SP15HBG2、SP30HBPS、SP25HBPS、SP15HBPS

1.2 Applicable personnel

This product is intended for use only by qualified personnel who are familiar with local regulations, standards, and electrical systems, have received professional training, and possess in-depth knowledge of this product.

1.3 symbol definition

To use this manual effectively, the following symbols are used to highlight important information. Please read the symbols and their descriptions carefully.

 danger
<ul style="list-style-type: none">● Indicates a situation with a high potential risk of death or serious injury if not avoided.
 warn
<ul style="list-style-type: none">● Indicates a moderate potential risk of death or serious injury if not avoided.
 take care
<ul style="list-style-type: none">● Indicates a low potential risk of moderate or minor harm to people if not avoided.
pay attention to
<ul style="list-style-type: none">● Emphasizing and supplementing the content may also provide tips or tricks for optimizing product usage, helping you solve a problem or save time.

2 Security

The safety precautions in this document must be strictly followed when operating the converter.

pay attention to

- The converter described in this document has been rigorously designed and tested in compliance with safety regulations. As an electrical device, it is imperative to follow the safety instructions before any operation, as improper handling may result in serious injuries or property damage.

2.1 General Description

pay attention to

- Due to converter version upgrades or other reasons, the document content may be updated periodically. Unless otherwise specified, the document content cannot replace the safety precautions in the product label. All descriptions in the document are for guidance only.
- Before installing the converter, please read this document carefully to understand the converter and precautions.
- All converter operations must be performed by certified electrical technicians who are thoroughly familiar with the local standards and safety regulations of the project site.
- The converter manufacturer shall not be liable for any damage to the converter or personal injury caused by improper installation, operation, or configuration as specified in this document or the corresponding user manual.

2.2 stringing safety

 warn

- Ensure the component border and bracket system are properly grounded.
- After completing the photovoltaic input cable connection, ensure the cable is securely fastened without any looseness.
- Use a multimeter to test the positive and negative terminals of the photovoltaic input cable, ensuring the correct polarity and voltage within the allowable range.
- Do not connect the same PV string to multiple hybrid inverters, as this may cause damage to the inverters.









2.3 hybrid converter safety

 warn

- Ensure that the voltage and frequency of the grid-connected access point meet the converter's grid connection specifications.
- It is recommended to install protective devices such as circuit breakers or fuses on the AC side of hybrid converters, with the device specifications exceeding 1.5 times the rated AC output current of the converter.
- The protective ground wire of the hybrid converter must be securely connected to ensure the impedance between the neutral wire and the ground wire is less than 10 Ω .
- For AC output lines, copper-core cables are recommended. If aluminum wire is required, use a copper-aluminum transition terminal to connect it to the converter.
- When the hybrid converter triggers overload protection, it automatically restarts.

 danger

- When installing the converter, avoid placing weight on its connectors to prevent damage.
- After installation, the converter must display clearly visible labels and warning signs, and any obstruction, alteration, or damage is strictly prohibited.
- The converter is labeled as follows:

	High voltage hazard. The converter operates at high voltage. Ensure the converter is powered off before operating it.		Delayed discharge. After the converter is powered down, wait 15 minutes for complete discharge.
	Before operating the converter, read the converter manual carefully.		The converter poses potential hazards when in operation. Take protective measures during operation.
	The converter surface is hot. Do not touch it during operation, as it may cause burns.		Grounding wire connection point.
	CE sign		Do not dispose of the converter as household waste. Dispose of it according to local laws and regulations, or return it to the manufacturer.

2.4 Battery safety



- Before installing the battery pack, carefully read the user manual to understand the product specifications and precautions. Follow all instructions in the manual strictly.
- If the battery pack is fully discharged, charge it strictly according to the user manual.
- The output capacity of the battery pack may be affected by environmental factors such as temperature, humidity, and weather conditions, potentially limiting its performance and consequently reducing the converter's load-carrying capacity.
- If the battery pack fails to start, contact customer service immediately to prevent permanent damage.
- Use a multimeter to test the positive and negative terminals of the battery pack's output cable, ensuring they are correctly connected to the converter's battery input interface. The battery output voltage must stay within the converter's allowable input voltage range.

2.5 Personnel Requirements

pay attention to

- The personnel responsible for installing or maintaining hybrid converters must undergo rigorous training, be fully aware of all safety precautions, and master the correct operational procedures for these systems.
- Only qualified professionals or trained personnel are allowed to install, operate, maintain, and repair the hybrid converter.

2.6 handling safety

When operating the converter, the operator must use insulated tools and wear safety protective equipment to ensure personal safety.

3 product presentation

3.1 product features

3.1.1 product orientation

This high-efficiency, high-reliability energy storage inverter is specifically designed for small and medium-sized energy storage microgrids. It supports photovoltaic grid integration, off-grid switching, parallel operation of multiple units, and hybrid operation with diesel generators, while enabling rapid on/off-grid switching. Ideal for backup power systems, load smoothing, peak shaving, small island microgrids, farms, villas, and battery cascading

applications, it caters to diverse user requirements.

3.1.2 product superiority

Efficient and highly reliable:

- (1) Low power consumption: standby power consumption $\leq 15W$, and no-load operation loss under off-grid conditions under 160W.
- (2) High efficiency: The maximum conversion efficiency reaches 97.8%.
- (3) High Protection: The core unit features IP5X protection rating, ensuring stable operation in harsh environments including sandstorms and high-salt fog.
- (4) Air duct isolation design: The isolation air duct design enhances product safety and reliability.
- (5) Exceeding overload capacity: Capable of handling 150% overload for short periods, enhancing system adaptability and durability.
- (6) Seamless switching capability: Enables seamless switching between grid-connected and off-grid modes, ensuring uninterrupted and stable power supply.

function :

- (1) Hybrid operation mode with diesel generator: Supports hybrid operation with diesel generator, providing flexible energy combinations and improving energy efficiency.
- (2) Three-phase independent grid-connected control technology: It realizes three-phase independent control, optimizes power distribution, and improves system flexibility and efficiency.
- (3) Seamless switching: seamless on/off grid switching (less than 10ms);
- (4) Grid adaptability: comprehensive high/low voltage ride-through capability, islanding protection, and black start functionality;
- (5) Parallel operation capability: The AC side supports 15 units in parallel operation (including 3 units with built-in STS function), while the DC side also enables multi-unit parallel operation.
- (6) Versatile applications: Ideal for small businesses, island microgrids, farms, villas, and other scenarios, meeting diverse user needs.

Convenience:

- (1) Communication and Monitoring: Supports multiple communication protocols and mainstream BMS systems, enabling remote monitoring and management.
- (2) High maintainability: front wiring and maintenance;
- (3) Fault protection: comprehensive fault protection and fault recording functions;
- (4) Efficient Energy Management: Featuring an integrated EMS (Energy Management System) that supports parallel operation of multiple devices, it enhances intelligent energy management capabilities, enabling self-consumption, economic operation modes, and grid priority.
- (5) Wide voltage range: Compatible with various battery configurations, offering strong adaptability to meet diverse energy demands across different capacities. Enhanced battery compatibility and superior cost-effectiveness, with a minimum voltage of 200V, such as 30kW/20-70kWh (100AH) and 30kW/(60-215)kWh (280AH).

3.1.3 Specification parameters

(1) Product Parameter

parameter	SP30HBG2	SP25HBG2	SP15HBG2
Battery parameters			
battery voltage range	200V-850V		
Supported battery types	lithium batteries, lead-acid batteries, etc.		
rated battery voltage range	320V-820V	320V-820V	200V-820V
maximum battery current	100A	80A	80A
PV parameter			
maximum power	19.2kW+19.2kW	15kW+15kW	15kW+15kW
Maximum PV voltage	850V		
rated PV voltage	600V		
PV starting voltage	250V		
MPPT voltage range	200V-800V		
overvoltage class	II level		
maximum feedback current	0A		
Maximum PV current	32A+32A	25A+25A	25A+25A

maximum short circuit current	35A+35A		
AC side (grid connection)			
power rating	30kVA	25kVA	15kVA
rated current	43.5A	36.2A	22A
rated grid voltage	400V/230V		
grid voltage range	-20%~15%		
initiation current	8.5A		
power frequency range	50Hz (47Hz~52Hz) or 60Hz (57Hz~62Hz)		
current harmonics	<3%		
power factor	-1~1		
overvoltage class	II level		
Protection level	I level		
AC side (off-grid)			
output rating	30kVA	25kVA	15kVA
maximum output	33kVA	27.5kVA	16.5kVA
rated output current	43.5A	36.2A	22A
maximum output current	48A	40A	24.2A
rated voltage	400V/230V		
output voltage harmonics	<3% (resistive load)		
degree of unbalancedness	100%		
frequency range	50/60Hz		
maximum fault current	472A/20ms		
maximum protected current of AC	48A	39.8A	24.2A
Output overload (current) Ie: Rated output current	Ie*1.1<Iload≤Ie*1.25		100s
	Ie*1.25<Iload		300ms
	Ie*1.25<Iload		300ms
system parameter			
Communication port	EMS: RS485		

	Battery: CAN or RS485
DIDO	DI: 2 channels; DO: 2 channels
maximal efficiency	97.8%
way to install	Insert frame (installed inside the cabinet)
loss	Standby power <15W, no-load power <160W
weight	≤35kg
size	W*L*H: 440*560*183mm
protect	IP20
temperature range	-30 to 60°C (use with reduced capacity when temperature exceeds 45°C)
Humidity range	5-95%
cooling-down method	Smart fan speed control and air cooling
class of pollution	II level
height	4000m (use at reduced rate for distances over 2000m)
attestation	CE, IEC62019, IEC62477, IEC61000, EN50549-1, AS4777.2
grid support	LVRT、HVRT、VSG

parameter	SP30HBPS	SP25HBPS	SP15HBPS
Battery parameters			
battery voltage range	200V-850V		
Supported battery types	lithium batteries, lead-acid batteries, etc.		
rated battery voltage range	320V-820V	320V-820V	200V-820V
maximum battery current	100A	80A	80A
AC side (grid connection)			
power rating	30kVA	25kVA	15kVA
rated current	43.5A	36.2A	22A
rated grid voltage	400V/230V		
grid voltage range	-20%~15%		

initiation current	8.5A		
power frequency range	50Hz (47Hz~52Hz) or 60Hz (57Hz~62Hz)		
current harmonics	<3%		
power factor	-1~1		
overvoltage class	II level		
Protection level	I level		
AC side (off-grid)			
output rating	30kVA	25kVA	15kVA
maximum output	33kVA	27.5kVA	16.5kVA
rated output current	43.5A	36.2A	22A
maximum output current	48A	40A	24.2A
rated voltage	400V/230V		
output voltage harmonics	<3% (resistive load)		
degree of unbalancedness	100%		
frequency range	50/60Hz		
maximum fault current	472A/20ms		
maximum protected current of AC	48A	39.8A	24.2A
Output overload (current) Ie: Rated output current	Ie*1.1<Iload≤Ie*1.25		100s
	Ie*1.25<Iload		300ms
	Ie*1.25<Iload		300ms
system parameter			
Communication port	EMS: RS485 Battery: CAN or RS485		
DIDO	DI: 2 channels; DO: 2 channels		
maximal efficiency	97.8%		
way to install	Insert Frame		
loss	Standby power <15W, no-load power <160W		
weight	≤35kg		

size	W*L*H: 440*560*183mm
protect	IP20
temperature range	-30 to 60°C (use with reduced capacity when temperature exceeds 45°C)
Humidity range	5-95%
cooling-down method	Smart fan speed control and air cooling
class of pollution	II level
height	4000m (use at reduced rate for distances over 2000m)
attestation	CE, IEC62019, IEC62477, IEC61000, EN50549-1, AS4777.2
grid support	LVRT、HVRT、VSG

3.1.4 product work characteristic curve

(2) curve of output

The power curve is shown in Figure 1.

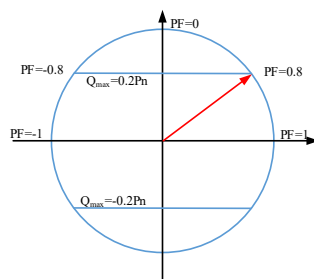

Figure 1 Power Curve

(3) battery voltage derating curve

The relationship between battery voltage and discharge power is illustrated in Figure 2.

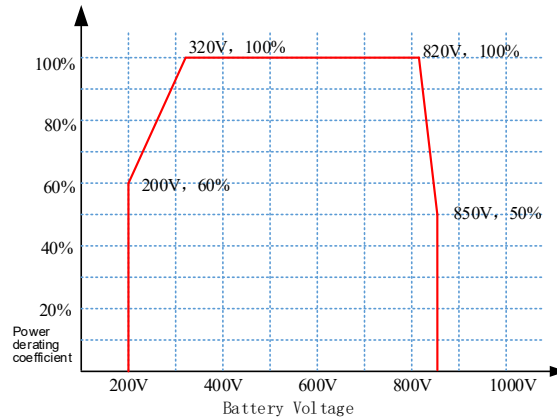

Figure 2 Relationship between Battery Voltage and Discharge Power

The relationship between battery voltage and charging power is illustrated in Figure 3.

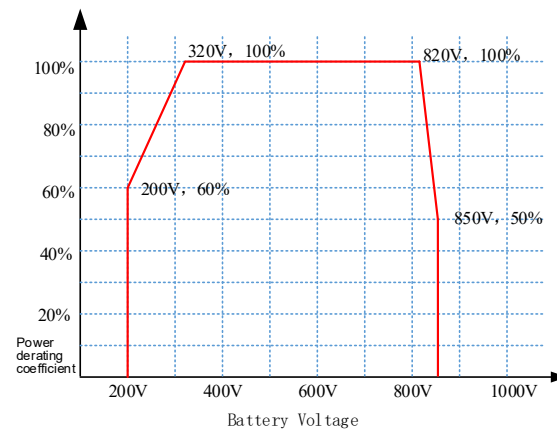

Figure 3: Battery Voltage vs. AC Charging Power

(4) grid voltage drop curve

The relationship between AC charge-discharge power and grid voltage is illustrated in Figure

4.

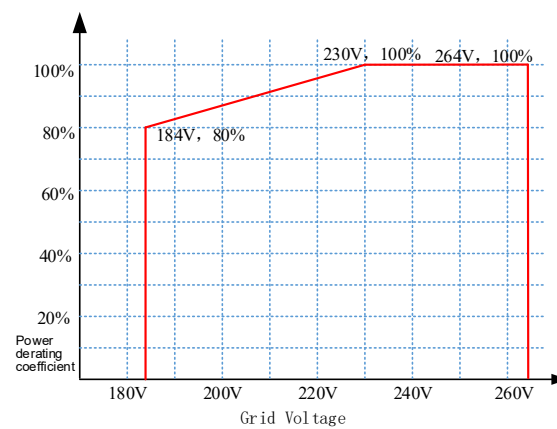

Figure 4: Relationship between AC charge/discharge power and grid voltage

(5) working environment temperature derating curve

The relationship between AC charge-discharge power and ambient temperature is illustrated in

Figure 5.

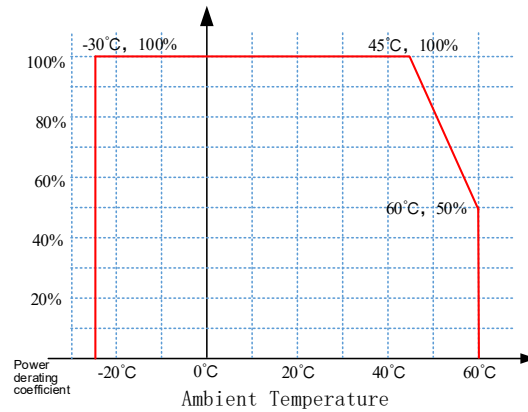

Figure 5 Relationship between AC charge/discharge power and ambient temperature

3.1.5 The differences among the four models are explained as follows

SP30HBG2: Rated power is 30kw, with a PV port

SP25HBG2: Rated power is 25kw, with a PV port

SP30HBPS: Rated power is 30kw, without PV port

SP25HBPS: Rated power is 25kw, without PV port

The hardware of the four models is the same, but the software is different. There are also differences in power and PV.

The PV port comes with a built-in protective cover when manufactured, and no personnel are required to install it manually.

3.2 Classic Product Applications

Classic applications are shown below:

- (1) Small-scale commercial and industrial facilities: Designed for small factories, commercial buildings, and office complexes, these systems optimize energy consumption through peak-valley pricing to reduce electricity costs. They also provide emergency backup power, ensuring critical equipment continues to operate smoothly during grid instability.
- (2) Microgrid for Small Islands: In remote islands or areas without stable grid coverage, the SP30HBG2 can integrate with renewable energy sources like solar panels and wind

turbines to establish an independent microgrid, ensuring a reliable power supply.

- (3) Farm and agricultural facilities: In the agricultural sector, this inverter can be integrated with solar and energy storage systems to power irrigation, greenhouse control, and automated equipment, while supporting an oil engine hybrid mode to ensure uninterrupted operation during energy shortages.
- (4) Villas and Residences: We provide energy solutions for high-end residences, integrating solar power generation with energy storage to boost energy self-sufficiency. Our systems also offer emergency power backup, ensuring uninterrupted household electricity during grid outages.
- (5) Temporary power and construction sites: In scenarios like construction sites, outdoor activities, and temporary facilities, the SP30HBG2 can serve as a portable power source to provide essential electricity. It also supports hybrid diesel generator operation, ensuring uninterrupted power supply.
- (6) Remote Areas and Emergency Rescue: In remote regions or emergency scenarios, the SP30HBG2 features lightweight design and high integration, with all-in-one rapid deployment. It ensures stable power supply and supports critical infrastructure like communication and medical equipment.
- (7) Battery recycling: Participate in national or regional energy optimization projects, such as wind-solar-diesel-storage island demonstration projects, to demonstrate the performance and benefits of SP30HBG2 in real-world applications.

3.2.1 industrial and commercial energy storage

Main application scenarios: homes, villas, supermarkets, farms, and outdoor construction sites.

Key functions: self-generated and self-used photovoltaic power, emergency backup power, etc.

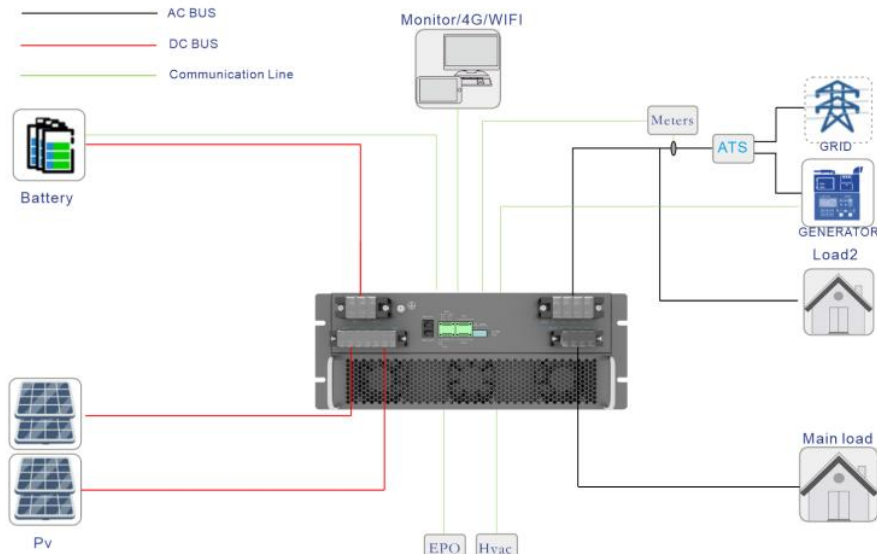

Figure 6

3.2.2 Off-grid Microgrid Solution

Main application scenarios: power instability areas, villas, farms, islands, oil extraction, and other off-grid regions.

Key functions: self-consumption, emergency backup power, generator management, fan management, etc.

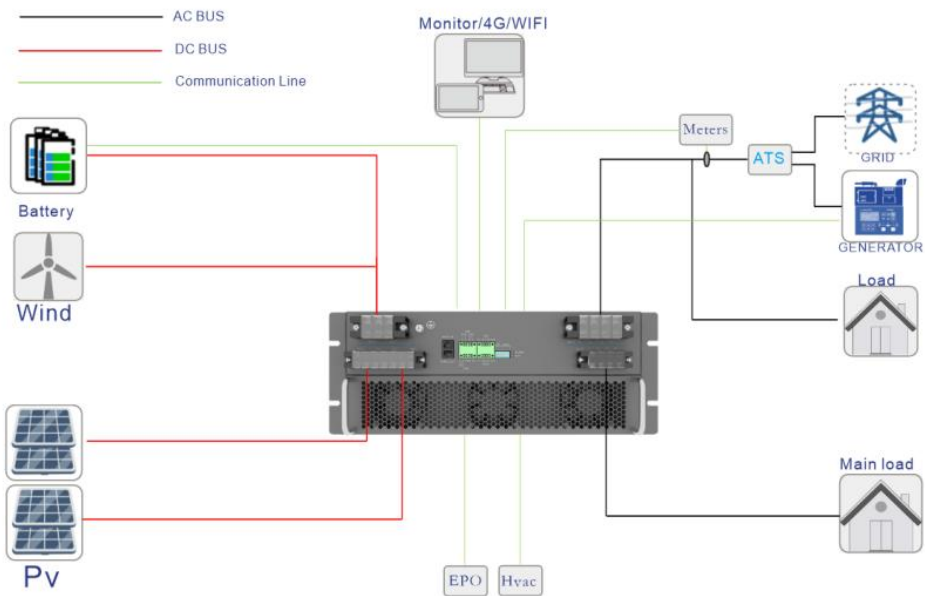

Figure 7

3.2.3 Three-phase unbalance and low voltage management

Key application scenarios: Terminal grid voltage issues (e.g., overvoltage, undervoltage, or imbalance) caused by renewable energy integration, load fluctuations, or line impedance.

Key features: Three-phase independent grid connection with autonomous control, ensuring energy balance and maximum compensation of 150%.

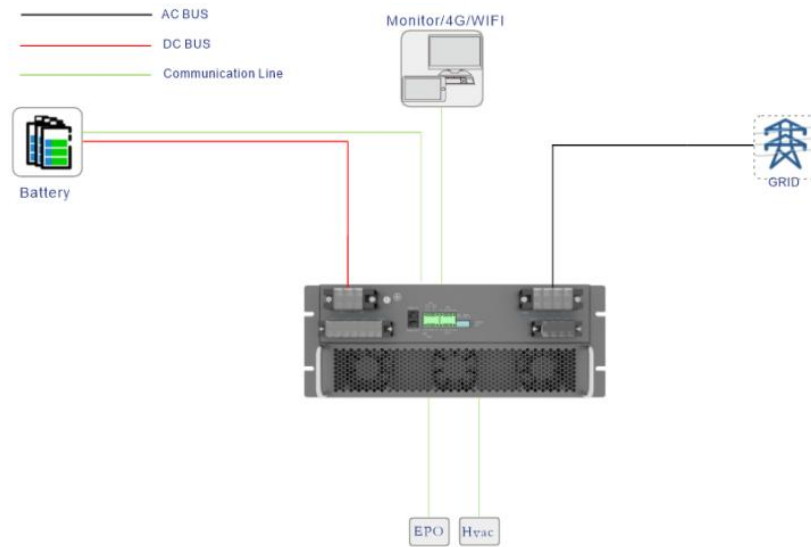

Figure 8

3.2.4 Energy Storage + Emergency Backup Power

Key applications: EPS replacement, power banks, battery recycling, sodium-ion batteries, fuel cells, and more.

Key features: Supports single-phase charging, with a wide battery power range (320V-820V) and a maximum current of 100A.

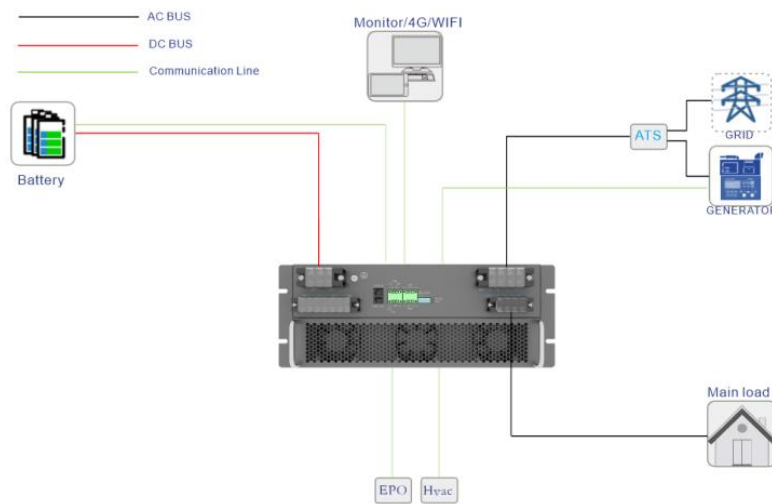

Figure 9

3.2.5 multi-unit parallel scheme

Key features: Supports multi-unit parallel operation, transformerless output, and transformer startup.

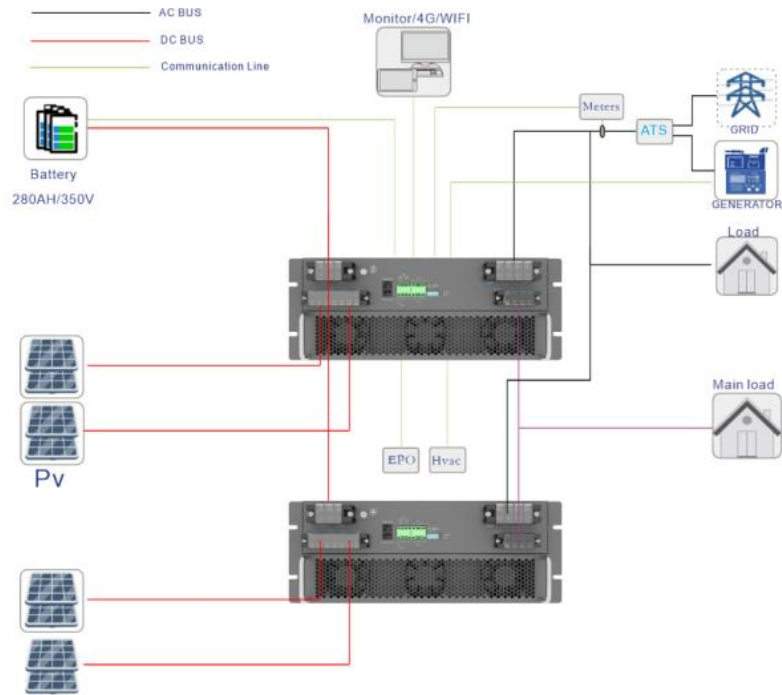

Figure 10

3.3 Model name rules

This document provides model specifications for SP**HB** series converters.

No.	Item	Description
1	corporate name	SP: Zhongteng Micro Network
2	alternating current rated power	30: Rated output power of AC 30kW 25: Rated output power of the AC system is 25kW 15: The rated output power of the AC is 15kW
3	DC voltage level	H: The DC input voltage ranges from 200 to 1000V.
4	levels of protection	B: Insert frame
5	Module Classification	G2: Hybrid Energy Storage Converter PS: Energy storage converter DC: DC transformer PV: DC MPPT IV: DC-to-AC converter

3.4 Product Circuit Introduction

3.4.1 Introduction to Power Circuits

As shown in Figure 11, the power circuit diagram indicates that the converter already incorporates a bus capacitor soft-start circuit, thus the BMS does not require a separate bus capacitor soft-start circuit.

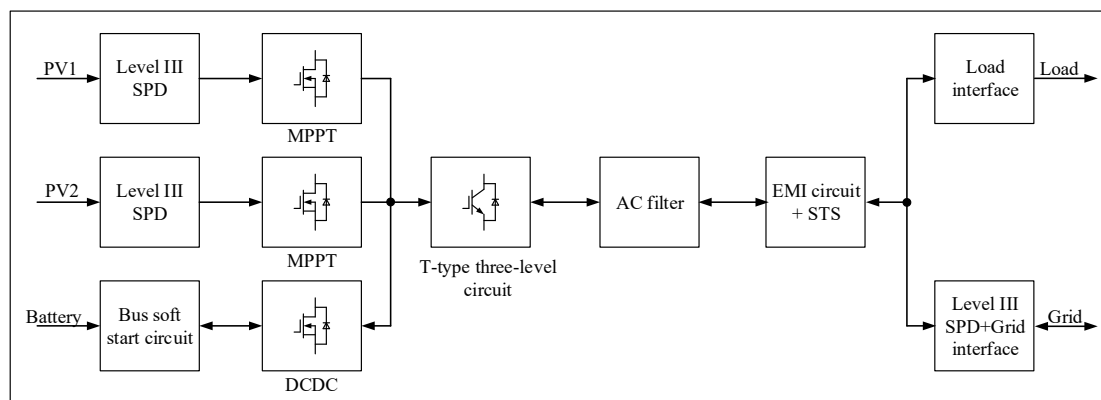

Figure 11 Schematic diagram of power circuit

3.4.2 Work Mode Introduction

The converter operates in three primary modes: self-consumption, energy-saving mode, and grid priority mode. These modes require an additional SAEMS100 controller. For details, please contact our sales team.

(1) self generated and self used

This model is designed for regions with relatively high electricity prices and low or no subsidies for grid-connected photovoltaic power. The system's core mechanism involves storing excess solar energy in batteries. When solar output is insufficient or during nighttime, the stored energy is released to power household loads. This approach enhances the photovoltaic system's efficiency and household energy self-sufficiency, while reducing reliance on grid electricity and lowering overall utility bills.

For instance: a) When solar PV systems receive sufficient sunlight (e.g., 35kW output) with a 10kW load, the 25kW surplus energy is stored in batteries instead of feeding back into the grid; b) When sunlight diminishes (e.g., 10kW output) with a 20kW load, the batteries compensate for the 10kW shortfall to meet the load's energy demand without consuming grid power.

(2) economic pattern

This mode is designed for scenarios with significant peak-valley electricity price differences, enabling peak-valley arbitrage. For example, during periods of relatively lower electricity prices, the converter is set to charge mode, while during periods of higher retail prices, it switches to grid-connected discharge mode. By manually configuring the converter's charging and discharging schedules, this mode automatically adjusts the converter's operational state according to time-of-use pricing.

(3) Preferential Internet Access

This model is designed for full-grid-connected scenarios to maximize photovoltaic power integration. When the PV generation exceeds the converter's rated AC-side output capacity, the excess energy is fed back to the battery. Conversely, if the PV output falls below the rated capacity, the battery supplements the deficit, ensuring the converter delivers maximum energy to the grid.

For example: a) When solar PV systems receive sufficient sunlight (e.g., 35kW output), the grid feeds back 30kW, leaving 5kW to charge the battery. b) When sunlight weakens (e.g., 10kW output), the grid still feeds 30kW, with the 20kW shortfall being covered by the battery to maximize grid feed-in power.

3.5 product mix

3.5.1 product appearance

(1) SP30-25-15HBG2 Product Appearance



Figure 12

(2) SP30-25-15HBPS Product Appearance

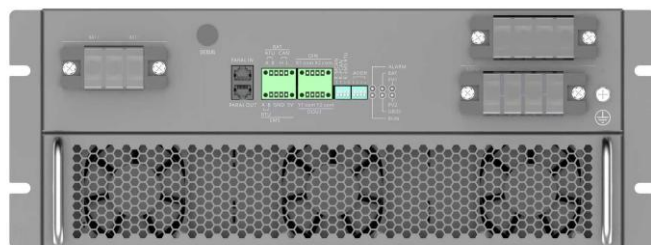

Figure 13

3.5.2 product appearance

(1) Product dimensions of SP30-25-15HBG2/SP30-25-15HBPS

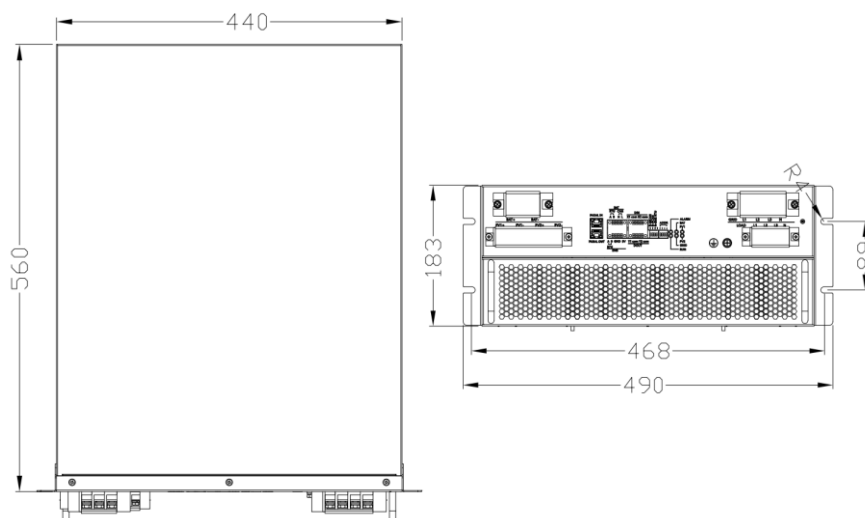

Figure 14

4 Transportation, storage, and installation



4.1 Transportation and storage

When transporting and storing converter modules, ensure compliance with the following requirements by following the markings on the packaging boxes.

⚠ take care	
<ul style="list-style-type: none"> ● Do not remove the converter's outer packaging during storage and transportation. ● Ensure the storage environment is free from corrosive and toxic gases. ● Ensure the storage temperature is maintained between -45°C and 70°C, with relative humidity kept within 5%RH to 95%RH. ● Ensure the storage stack is stacked up to 4 layers without any risk of tipping over. ● During storage, regular inspections should be conducted. If signs of insect infestation or rodent damage are detected, the packaging materials must be replaced promptly. ● Ensure that transport vehicles and storage warehouses meet fire safety requirements; ● If stored for more than six months, the converter must undergo inspection and testing by qualified personnel before being put into service. ● Avoid transporting the converter in rain or adverse weather conditions. If unavoidable, take necessary protective measures. ● For long-term storage, ensure that the device is powered on annually from the date of purchase, with each power-on session lasting no less than 6 hours. 	

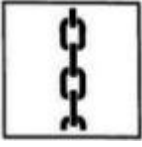
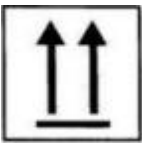
The labeling diagram for packaging is shown in the table below.

icon	explain
	The center of gravity marker indicates the location of the energy storage converter's center of gravity.
	Lifting sign indicating the chain or rope position during energy storage converter hoisting.
	The upward sign indicates the proper placement method for energy storage converters during handling and installation. Inversion, horizontal placement, or tilting is strictly prohibited.

	Handle with care and avoid vigorous friction or impact during transportation and storage.
	Moisture-sensitive label: During transportation and storage, protect the energy storage converter from rain or moisture exposure.

4.2 Unboxing and inspection

When unpacking the converter, the following checks must be performed:

 warn	
●	Before opening the box, inspect the converter's outer packaging for any damage. If damage is found, contact the relevant personnel immediately for confirmation and replacement.
●	Place the converter on a level surface with its top facing upward, then remove the sealing tape from the outer packaging.
●	Review the shipping documents to verify for any missing or misissued attachments. If any are found, contact the responsible personnel immediately to confirm and reissue the missing documents.
●	Remove the filling buffer cotton, and then two or more people should assist each other to remove the converter module, to prevent the converter from falling when removing the converter module, which may threaten life and property safety.
●	Inspect the plastic film packaging bag of the converter module for any damage. If damage is found, contact the relevant personnel immediately for confirmation and replacement.
●	Remove the plastic film from the module and inspect its surface for any visible scratches or defects. If such defects are found, contact the relevant personnel immediately for verification and replacement.
●	Verify that the converter module's nameplate parameters (including model, rated power, voltage range, and other key specifications) match the order contract. If discrepancies are found, contact the relevant personnel immediately for verification and replacement.
●	Properly dispose of converter-related packaging materials in accordance with local laws and regulations.



4.3 handling and installation

4.3.1 Installation and Handling Precautions

The transportation, storage, or installation of converters must comply with the laws, regulations, and relevant standards of the country or region where they are located. Before installation, the hybrid converter must be transported to the installation site. During transportation, please note the following precautions to avoid personnel injuries or equipment damage:

⚠ warn	
<ul style="list-style-type: none"> ● Ensure the right number of personnel is assigned based on the hybrid converter's weight to prevent injuries from exceeding the human carrying capacity. ● Wear safety gloves when installing or moving a hybrid converter to avoid injury. ● Ensure the converter remains balanced during handling to prevent drops. 	

4.3.2 replacement tool

tool		
forklift	torque spanner	bolt driver
		
<p>When handling short-distance equipment, forklifts should be used to avoid falls that could cause injuries or equipment damage.</p>	<p>When connecting power cables, use a torque wrench to apply the correct torque. Insufficient torque may cause unstable connections, while excessive torque could damage the terminals.</p>	<p>Crosshead screwdriver for M6 screws, used to secure modules in the cabinet</p>

4.3.3 Installation environment

The installation environment of the converter must meet the following requirements:

⚠ take care

- The converter must be installed in a shaded location to avoid direct sunlight exposure.
- The converter should be installed in a well-ventilated area to prevent poor heat dissipation from affecting its performance.
- During operation, the converter's surface temperature may rise significantly. Always install it in a location inaccessible to direct contact.
- Converters must be kept away from children and special populations;
- The converter installation area should be kept away from flammable and explosive materials, and also from strong interference equipment.
- The mounting frame or wall of the converter should have certain fireproof performance.
- The converter should be avoided to be installed in the office area or residential area which is sensitive to noise.

To ensure the safety of installation personnel, appropriate safety measures must be implemented when performing electrical installation or maintenance on this product. The following procedures must be followed during electrical installation:



- Disconnect all power sources connected to the converter and ensure it is fully de-energized.
- A warning sign must be left at the disconnected position to prevent re-powering during installation.
- The necessary grounding and short-circuit connections must be made.
- The live parts should be treated with necessary measures and isolated with insulating materials to prevent injuries to personnel.
- Professional personnel must perform the converter installation, strictly following the user manual during the process.
- Installation personnel must comply with the relevant electrical operating procedures of their country or region.
- The installation team must first understand the voltage level of the power supply area to determine the appropriate voltage compatibility.

The converter has the following environmental requirements:、



- This product is installed in a cabinet and must be deployed in the final system.
- The installation must be at an altitude not exceeding 4000 meters. If the altitude exceeds 2000 meters, the rated capacity must be reduced.
- The converter operates within a temperature range of -30°C to $+60^{\circ}\text{C}$. When ambient temperature exceeds 45°C , the converter must be used at reduced capacity.
- The converter operates in a humidity range of 5%RH to 95%RH with no condensation.
- When the converter is working in high dust environment, the dust filter should be added according to the situation, but the air inlet and air outlet of the converter will not be affected.

4.3.4 air duct requirements

The converter module employs forced air cooling with the front panel serving as the air intake and the rear panel as the exhaust outlet. The module's rated air intake capacity is 350 CFM (10m³/min). When installed in an integrated system, the cabinet's air intake must directly face the module's front intake, with a minimum distance of 110mm between the intake and cabinet enclosure. The cabinet should also incorporate dedicated air ducts and exhaust ports aligned with the module's exhaust and the cabinet's outlet, maintaining a minimum distance of 110mm to ensure direct airflow discharge and prevent internal recirculation. Where dedicated exhaust ports are unavailable, a fan should be installed at the cabinet's outlet, with airflow capacity twice the module's intake requirement. To accommodate dustproof padding, the cabinet's intake area should be three times larger than the module's intake area, using 40PPI polyurethane mesh foam with 94V0 flame retardancy rating. The cabinet's exhaust area should double the module's exhaust area, equipped with a 10-mesh insect-proof steel mesh. Refer to the diagram below for intake specifications.

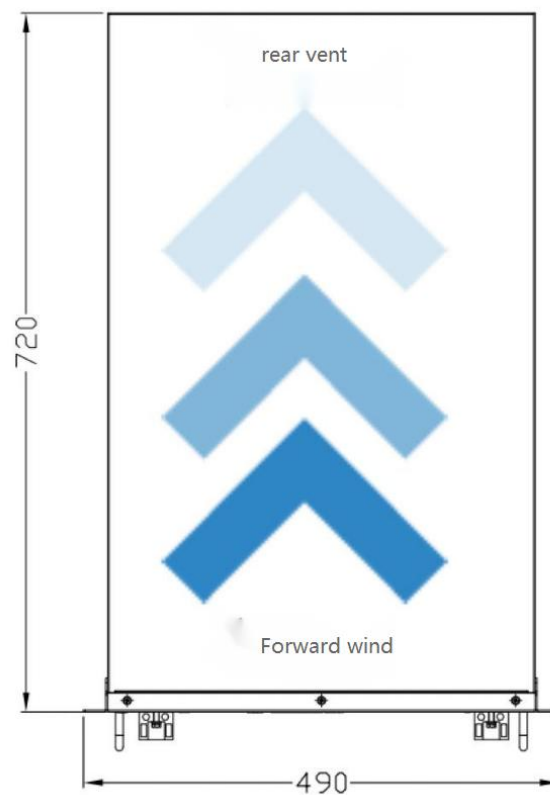

5 Cable Connection Instructions

5.1 Port definition

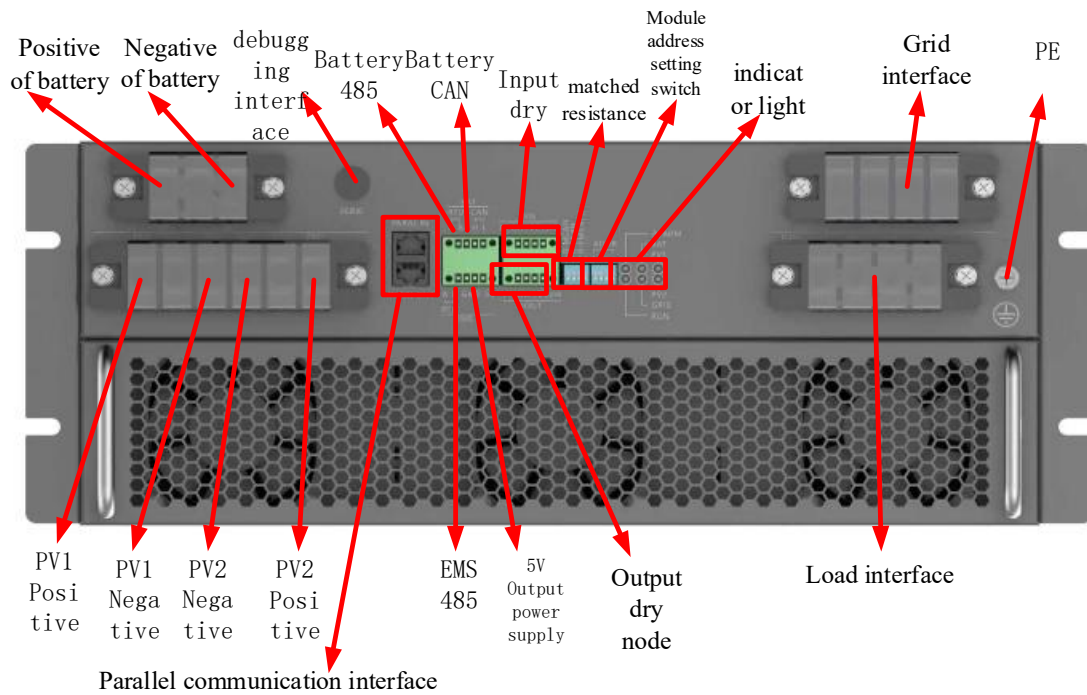

Figure 15 Port definition schematic

Power port definition:

Name	Description	Remarks
BAT+/BAT-	battery input terminal	OT terminal (RNB22-6S), recommended 25mm ² cable
LOAD (L1/L2/L3/N)	AC load terminal	OT terminal (RNB22-6S), 16mm ² cable
GRID (L1/L2/L3/N)	AC power supply terminal	OT terminal (RNB22-6S), recommended 25mm ² cable
PV1+/PV1-/PV2V-/PV2+	photovoltaic input terminal	OT terminal (RNB14-6S), recommended 10mm ² cable
PE	earth terminal	OT terminal (RNB14-6S), recommended 10mm ² cable



- The power terminal is secured with M6 screws. Always use the included screws to fasten the power cable, applying a torque of 3N·m (30kgf·m). Excessive torque may damage the terminal, while insufficient torque may cause poor contact.
- The module must be reliably grounded during operation, as poor grounding may cause electric shock hazards and module damage. The tightening torque for the fixing screws is 5 N·m.

The signal terminal interface definition is shown in Figure 16.

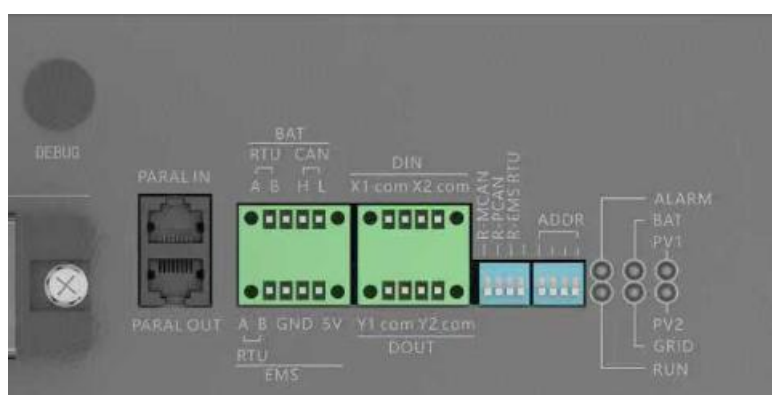

Figure 16 Signal Terminal Interface Definition

Name	Description	Remarks
PARAL IN	parallel line input	parallel line
PARAL OUT	parallel line output	parallel line
BAT_RTU	Battery RS485 interface	BAT communication interface
BAT_CAN	Battery CAN interface	
RTU(A-B)	EMS communication interface	The host computer, EMS, or SAEMS100 (optional) coordinates the control system.
5V-GND	SAEMS power supply port	Output capacity: 5V/1A
X1	input dry node	scram button
X1_com	input dry node	
X2	input dry node	obligate
X2_com	input dry node	obligate
Y1	output dry contact	Output capability: The maximum voltage of the port is 24V, and the maximum current is 200mA.
com		
Y2	output dry contact	
com		
R-MCAN	parallel communication	ON: indicates the communication matching

	matching resistor	resistor is connected
R-PCAN	parallel communication matching resistor	The first and last modules must be equipped with parallel communication matching resistors (set to ON via the dialer), while the rest need not.
R-EMS RTU	EMS RTU communication matching resistor	
ADDR	module address dial	ON: represents 1, otherwise 0 The module address is represented in binary format, with the left side being the high bit and the right side the low bit. For example, module 1 is represented as 0001, and module 3 as 0011.
DEBUG	debugging interface	For internal debugging only
ALARM	fault indicating lamp	The indicator light of the converter is on when it is faulty and off when it is not.
RUN	status indicator light	The indicator light stays on during normal operation, flashes once per second in standby mode, and turns off when a fault occurs.
BAT	battery status indicator	The battery circuit function remains illuminated during normal operation. When the battery is functioning normally, it flashes once per second; when malfunctioning, it turns off.
GRID	power state indicator	The indicator stays on during grid-connected operation, flashes once per second when the grid is normal, and turns off when grid abnormalities occur.
PV1	PV1 status indicator light	PV1 remains illuminated during operation. When functioning normally, it flashes once per second; when malfunctioning, it turns off.
PV2	PV2 status indicator light	PV2 remains illuminated during operation. When functioning normally, it flashes once per second; when malfunctioning, it turns off.

The internal schematic diagram of the output dry node is shown in Figure 17.

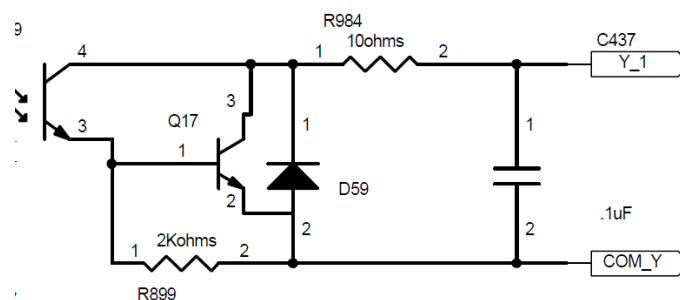

Figure 17 Internal principle of output dry node

The maximum voltage of the port should not exceed 24V, and the maximum current should not exceed 200mA.

The internal schematic diagram of the input dry node is shown in Figure 18.

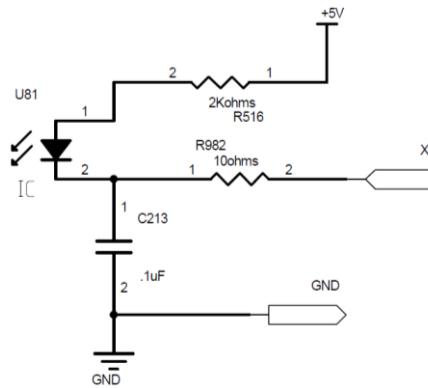







Figure 18 Internal schematic diagram of the input dry node

The input dry terminal is pre-installed with a power supply, requiring only an external switch for short-circuit connection. The total impedance of the switch and line must be less than 0.1Ω.

5.2 cable wiring tool

Tools and Instruments		
multimeter  Check the equipment's live condition	torque spanner  Connect the power cable, torque 3N·m (30kgf/m)	Wire clamp  For power cable crimping
bolt driver  Cross screwdriver for tightening and removing M6 screws	connection cover cutting pliers  For power cable processing	Hot air gun (or hot air blower), heat shrink sleeve  Wrap the conductive part of the power cable to prevent electrical leakage

Add necessary tools based on the site conditions to prevent installation delays caused by tool shortages.

5.3 DC side wiring



- The battery voltage must not exceed the converter's maximum DC voltage of 850V, as exceeding this limit may cause equipment damage.
- When a grounding fault occurs in the system, the fault must be resolved before proceeding with wiring.
- The DC power cable screws of the converter must be tightened to 3N.m torque. If the torque is less than this, poor contact may cause fire; if greater, it could damage the power terminals.
- If the converter wiring is incorrect, it may cause the converter to malfunction and even damage the equipment.
- During installation, follow the cable installation sequence strictly to prevent accidents.

The installation sequence for battery side cables is as follows:

Step 1: Measure the battery's terminal voltage with a multimeter to verify it falls within the converter's input voltage range.

Step 2: Disconnect the battery switch and use a multimeter to verify that the power cable for the converter is unpowered.

Step 3: Cut a heat-shrink sleeve to the required length and attach it to the power cable for crimping.

Step 4: Use a wire stripper to remove the insulation from the power cable to the required length, then install the cold-pressed terminals that match the terminal block, and finally secure them with a crimping pliers.

Step 5: After completing the terminal crimping, verify its reliability. If the crimping is insufficient, trim the terminal and repeat Step 4.

Step 6: After securing the terminal crimping, use a heat gun to shrink the heat-shrink sleeve and complete the insulation.

Step 7: Connect the battery pack's positive and negative power cables to the converter's terminals "BAT+" and "BAT-", then use a torque wrench to apply the required torque for calibration, ensuring proper contact between the power cables and terminals.

5.4 AC side wiring



- The grid voltage must not exceed the converter's maximum allowable AC voltage of 264V, as exceeding this limit may cause equipment damage.
- When a ground fault occurs in the system, the fault must be cleared before proceeding with wiring.
- The AC power cable screws of the converter must be tightened to a torque of 3N.m. If the torque is less than this, poor contact may cause a fire. If the torque exceeds this, it may damage the power terminals.
- If the phase sequence is incorrect during installation, the converter may fail to operate properly or even be damaged.
- During installation, follow the cable installation sequence strictly to prevent accidents.

The installation sequence for AC side power cables is as follows:

Step 1: Use a multimeter to measure the grid's terminal voltage (phase voltage below 264V) and verify it falls within the converter's input voltage range.

Step 2: Disconnect the power grid switch, then use a multimeter to measure the AC power cable and converter terminals. Ensure both the AC power cable to be installed and the converter terminals are unpowered.

Step 3: Cut a heat-shrink sleeve to the required length and attach it to the power cable for crimping.

Step 4: Use a wire stripper to remove the insulation from the power cable to the required length, then install the cold-pressed terminals that match the terminal block, and finally secure them with a crimping pliers.

Step 5: After completing the terminal crimping, verify its reliability. If the crimping is insufficient, trim the terminal and repeat Step 4.

Step 6: After securing the terminal crimping, use a heat gun to shrink the heat-shrink sleeve and complete the insulation.

Step 7: Connect the power cable to the converter's grid-side terminals (L1, L2, L3, and N). Use a torque wrench to apply the correct torque for calibration, ensuring proper contact between the power cable and the terminals.

Step 8: Connect the AC load power cable to the 'L1', 'L2', 'L3' and 'N' terminals on the

converter's load side. Use a torque wrench to apply the correct torque during installation, ensuring proper contact between the power cable and the terminals.

5.5 Setting earth fault alarms notification

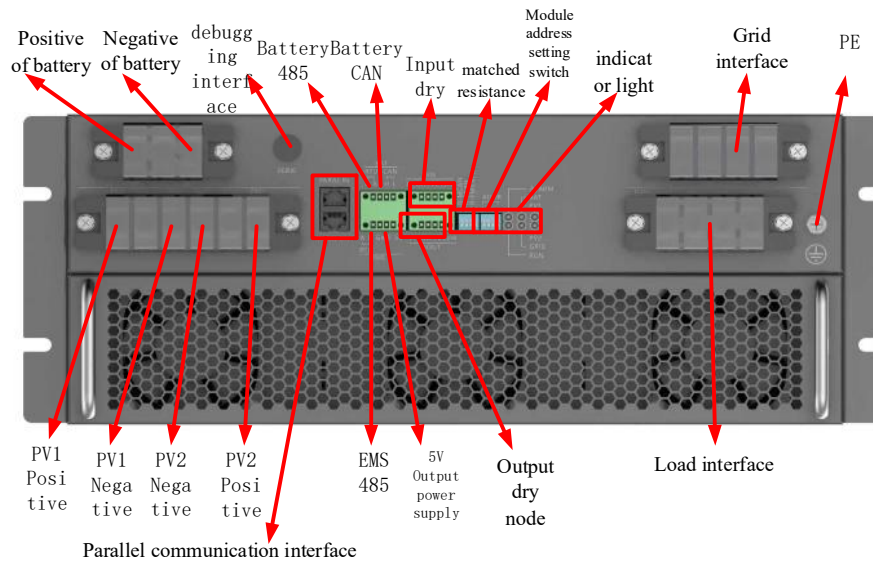

Figure 4 Port Definition Diagram

Name	Function	Note
PE	Ground terminal	OT terminal (RNB22-6S), recommended 10mm ² cable

Connect the PE terminal on the inverter panel to the ground effectively. When the inverter is turned off, it will automatically detect whether the grounding is abnormal. If there is an abnormality, the panel of the machine will light up a red light, and at the same time, the bit 2 of the register address 53 of the Modbus 485 protocol can be used to monitor whether a grounding anomaly has occurred.

5.6 Wiring diagram

This section mainly illustrates the wiring diagram of a cluster with a single management unit, a cluster with multiple management units in parallel, and a single battery pack with multiple units in parallel.

Attention

- Ensure the battery pack addresses match the converter addresses one-to-one to prevent inaccurate EMS control caused by PCS-battery pack mismatch.
- The SAEMS100 or SAEMS200 must communicate with all battery packs using either RTU or CAN communication. Either method is acceptable, with RTU operating at 115.2 kbps and CAN at 125 kbps.
- The SAEMS100 or SAEMS200 communicates with the converter via RTU and CAN protocols. Both protocols require connection, and the RTU and CAN communication cables for all parallel converters must be connected separately.
- Ensure the matching resistor for RTU and CAN communication in the final converter module is enabled.
- Ensure all parallel converters have unique addresses (change converter addresses via dial-up settings), with RTU communication at 115200 baud and CAN communication at 125kbps.
- The SAEMS100 or SAEMS200 communicates with the electricity meter via RTU at a baud rate of 9600, primarily to enable the external anti-backflow function.
- SAEMS100 or SAEMS200 are available for purchase. For purchasing, please contact the relevant staff.
- STS is a product selection service. For purchasing, please contact our staff.

5.6.1 Cluster and Single Machine Connection Diagram

The wiring diagram of this operational mode is shown in Figure 19. All power cables connected to the converter must be equipped with external disconnect switches. The converter can operate in either grid-connected or off-grid mode, with automatic switching capability between the two states. The SAEMS100 system coordinates control of the entire setup based on user-defined parameters, enabling the system to adapt to diverse operational requirements.

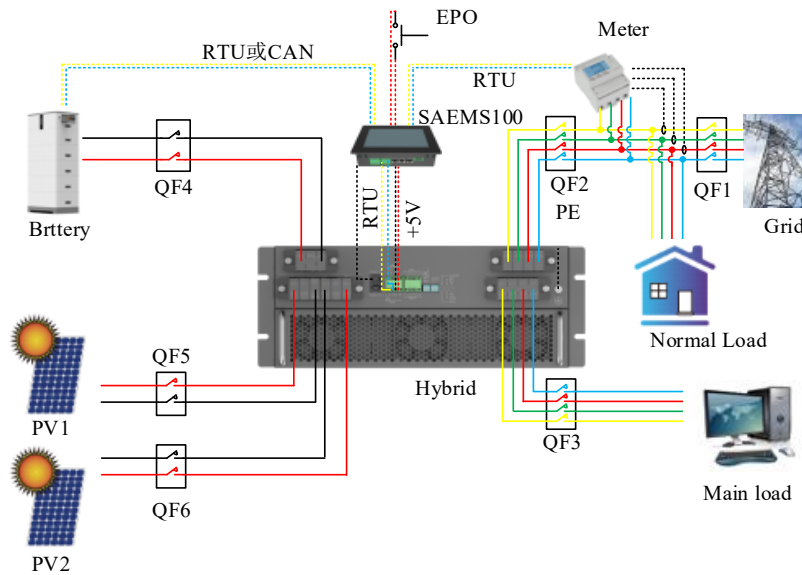

Figure 19 Schematic diagram of one-cluster-one-management wiring

Warning

- When using a photovoltaic simulator or DC power supply to replace solar panels for testing, first close the isolating switches QF5 and QF6 before powering on the simulator or DC power supply.
- For electricity meter selection, the Acrel ADL400 model is recommended.
- The CT must be installed between the load and QF1; otherwise, the intended effect cannot be achieved.
- If the electricity meter is not installed, the inverter's internal anti-reverse flow function can be enabled. In this case, the load is powered by the grid, and the inverter only supplies power to critical loads.
- The converter must be reliably grounded to prevent personal injury and equipment damage.

5.6.2 One cluster, one management, multiple machines in parallel (off-grid)

The wiring diagram of this operational mode is shown in Figure 20. All power cables connected to the converter must be externally equipped with disconnect switches, and the converter is exclusively designed for off-grid operation. The system supports a maximum of 15 parallel-connected units, with each converter's battery side linked to an independent battery pack for one-to-one management. The SAEMS200 system coordinates control based on user-defined parameters, enabling customized operation to meet diverse user requirements.

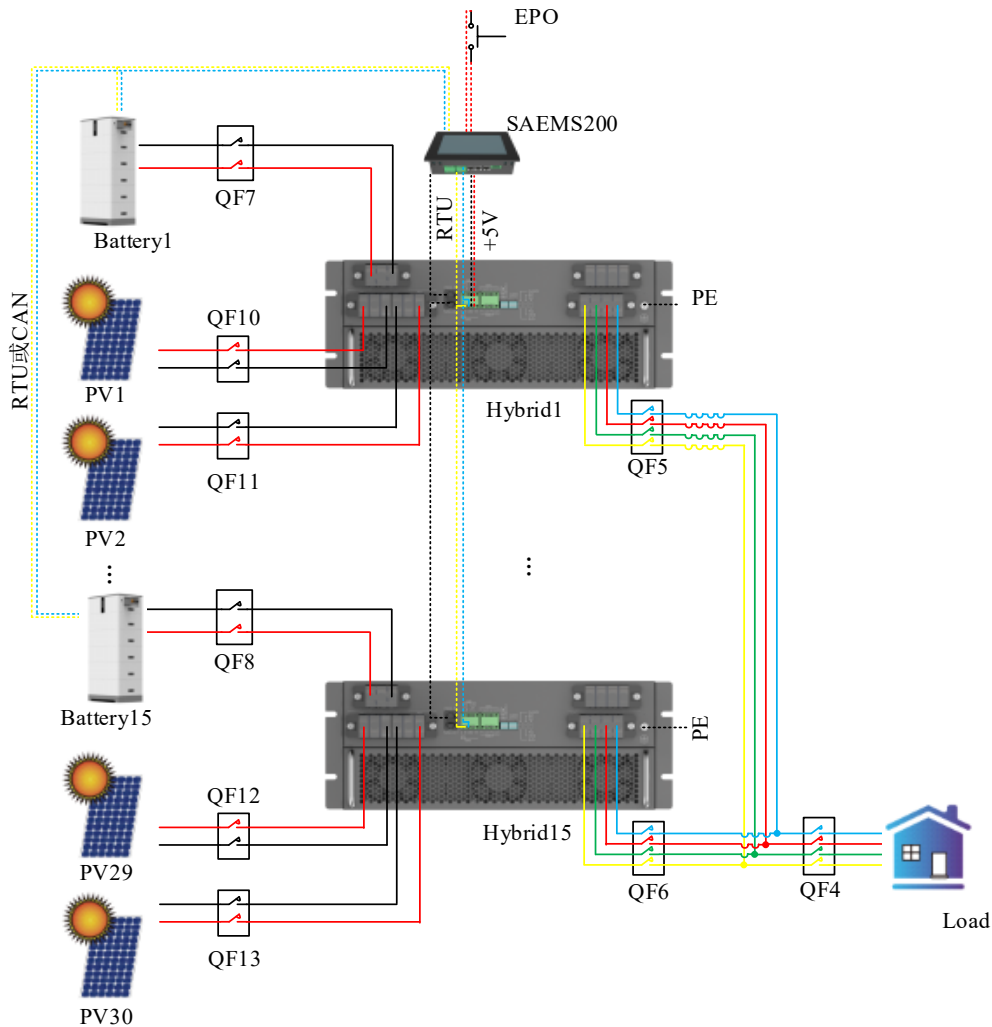

Figure 20 Schematic diagram of multi-machine parallel connection with one cluster and one management

Warning

- When using a photovoltaic simulator or DC power supply to replace solar panels for testing, first close the circuit breakers QF10, QF11, QF12, and QF13, then power on the simulator or DC power supply.
- When this wiring mode is adopted, the converter can only operate in off-grid mode and cannot be connected to the grid.
- All inverters must be reliably grounded to prevent personal injury and equipment damage.

5.6.3 One cluster, one management, multiple machines in parallel (with off-grid switching capability)

(1) Use cases with up to 3 parallel devices

The wiring diagram of this operational mode is shown in Figure 21. The converter can autonomously perform grid-connection and off-grid switching functions, with a maximum of three parallel-connected units. All power cables must be connected to external disconnect switches. The

SAEMS100 system coordinates and controls the entire setup based on user-defined parameters, enabling customized operation to meet diverse user requirements.

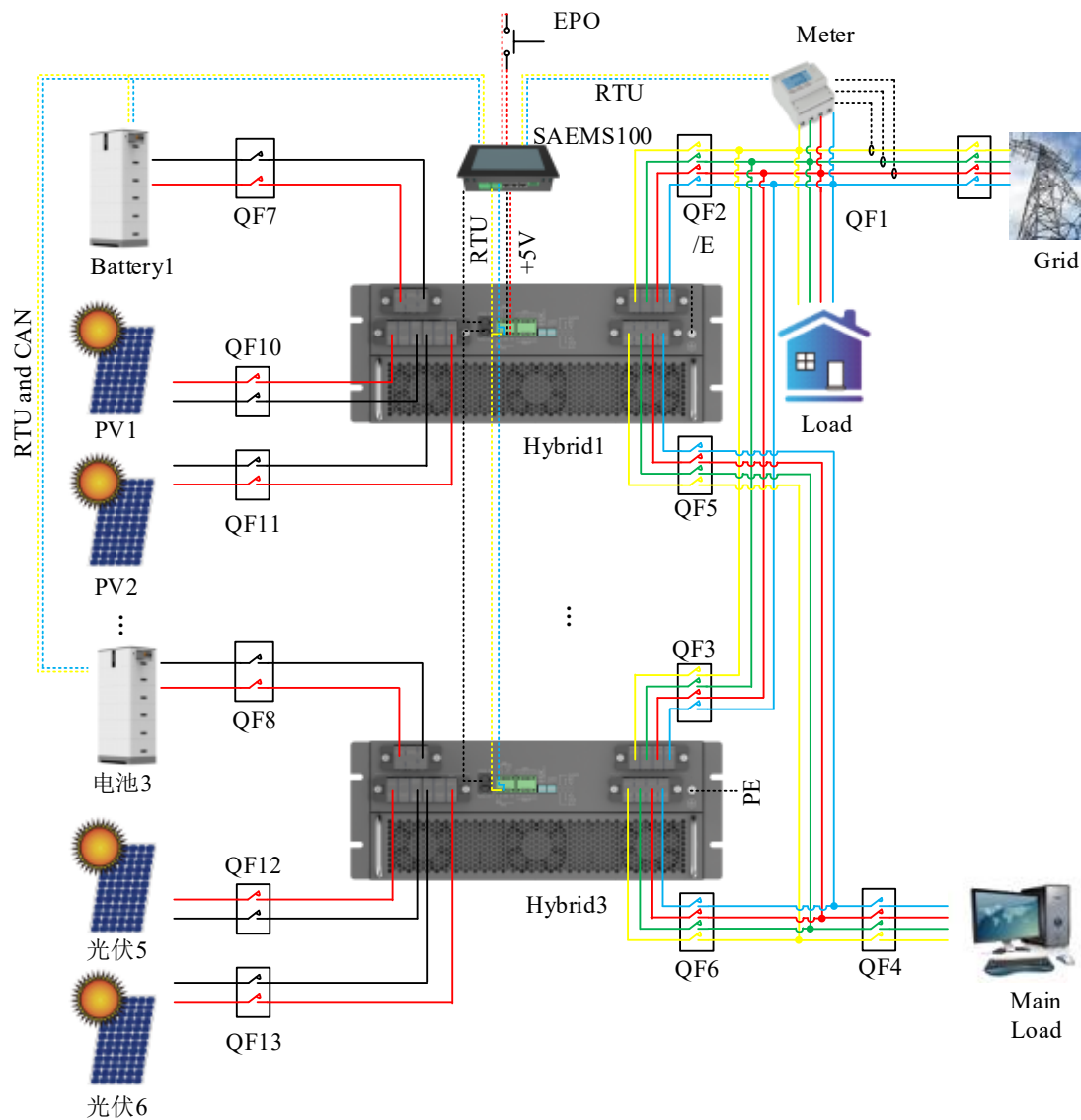

Figure 21 Schematic diagram of multi-machine parallel connection with one cluster and one management

Warning

- When using a photovoltaic simulator or DC power supply to replace solar panels for testing, first close the circuit breakers QF10, QF11, QF12, and QF13, then power on the simulator or DC power supply.
- For electricity meter selection, the Acrel ADL400 model is recommended.
- The CT must be installed between the load and QF1; otherwise, the intended effect cannot be achieved.
- If the electricity meter is not installed, the inverter's internal anti-reverse flow function can be enabled. In this case, the load is powered by the grid, and the inverter only supplies power to critical

loads.

- All inverters must be reliably grounded to prevent personal injury and equipment damage.

(2) Use cases with more than 3 parallel devices

The wiring diagram of this operational mode is shown in Figure 22. The converter must work in conjunction with an external STS device to enable grid-connection/disconnection switching, supporting up to 15 parallel-connected units. All power cables feeding the converter require external disconnectors. The SAEMS200 system coordinates control based on user-defined parameters, enabling customized operation to meet diverse user requirements.

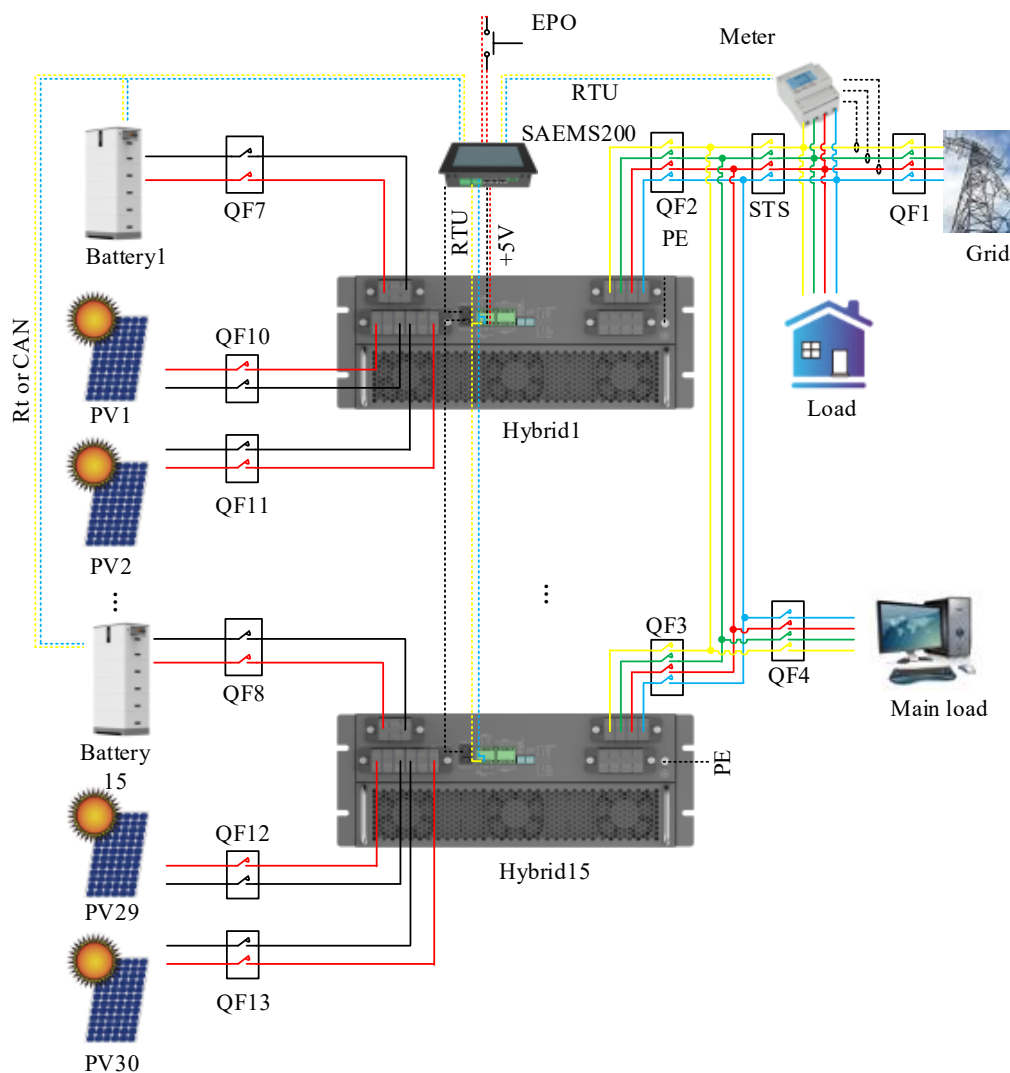

Figure 22 Schematic diagram of multi-machine parallel connection with one cluster and one management

Warning

- When using a photovoltaic simulator or DC power supply to replace solar panels for testing, first close the circuit breakers QF10, QF11, QF12, and QF13, then power on the

simulator or DC power supply.

- For electricity meter selection, the Acrel ADL400 model is recommended.
- The CT must be installed between the load and QF1; otherwise, the intended effect cannot be achieved.
- If no electricity meter is installed, enable the STS's internal anti-reverse flow function. In this case, the load is powered by the grid, and the converter only supplies power to critical loads.
- All converters and STS must be reliably grounded to prevent personal injury and equipment damage.

5.6.4 Schematic diagram of multi-unit parallel connection of single battery pack (off-grid)

The wiring diagram of this operational mode is shown in Figure 23. The system supports up to 15 parallel-connected converters, which must operate in off-grid mode exclusively. All power cables must be connected to external disconnect switches. The SAEMS200 system coordinates control based on user-defined parameters, enabling customized operation to meet diverse user requirements.

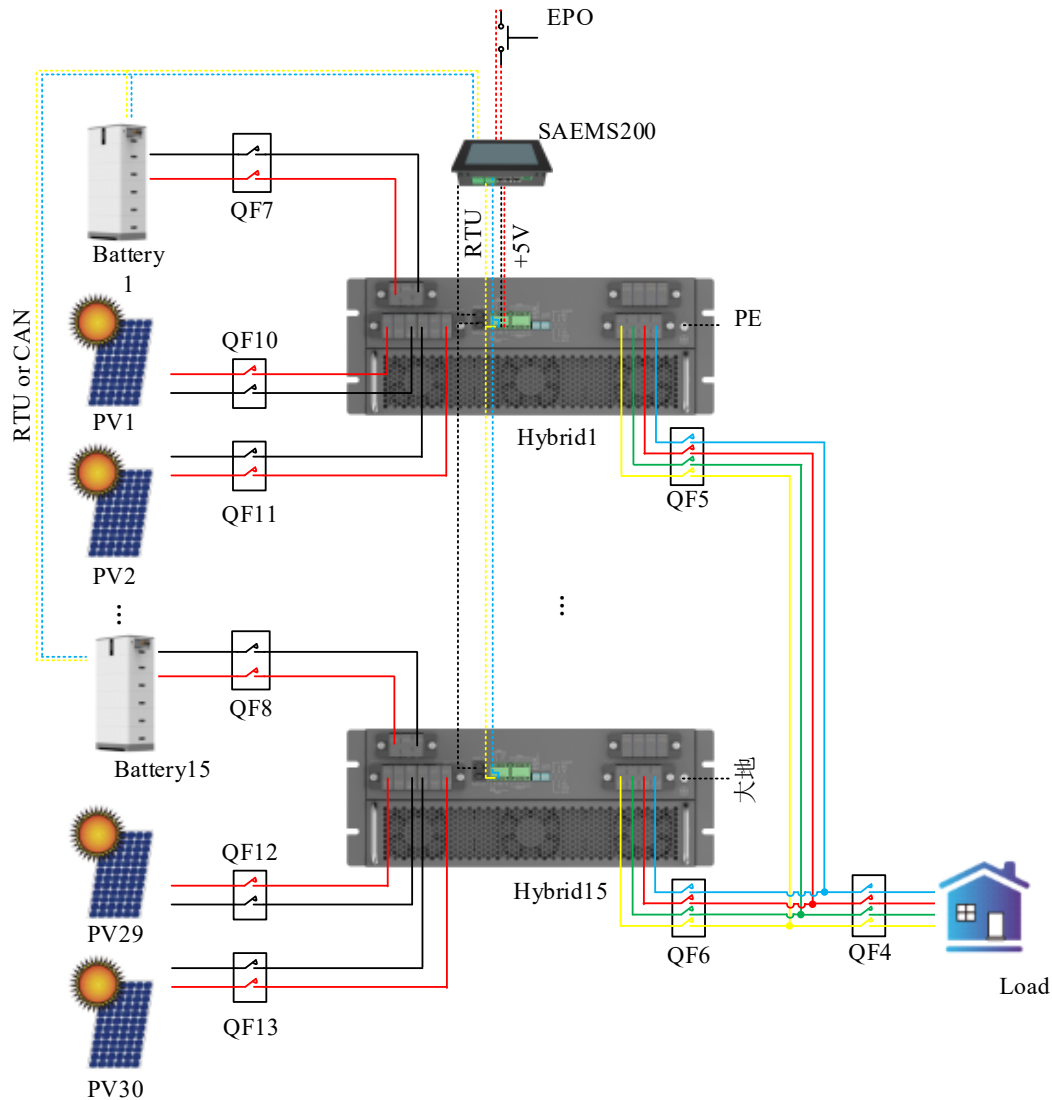

Figure 23 Schematic diagram of multi-unit parallel connection for single battery pack

Warning

- When using a photovoltaic simulator or DC power supply to replace solar panels for testing, first close the circuit breakers QF10, QF11, QF12, and QF13, then power on the simulator or DC power supply.
- This wiring method is only applicable in off-grid mode and cannot operate in grid-connected mode.
- All inverters must be reliably grounded to prevent personal injury and equipment damage.

5.6.5 Schematic diagram of multi-unit parallel connection with single battery pack (including grid connection/disconnection switching)

(1) Use cases with up to 3 parallel devices

The wiring diagram of this operational mode is shown in Figure 24. The parallel configuration

features built-in grid-connection/disconnection switching capability, supporting up to three parallel units. All power cables connected to the converter require external disconnect switches. The SAEMS100 system performs coordinated control based on user-defined parameters, enabling customized operation to meet diverse user requirements.

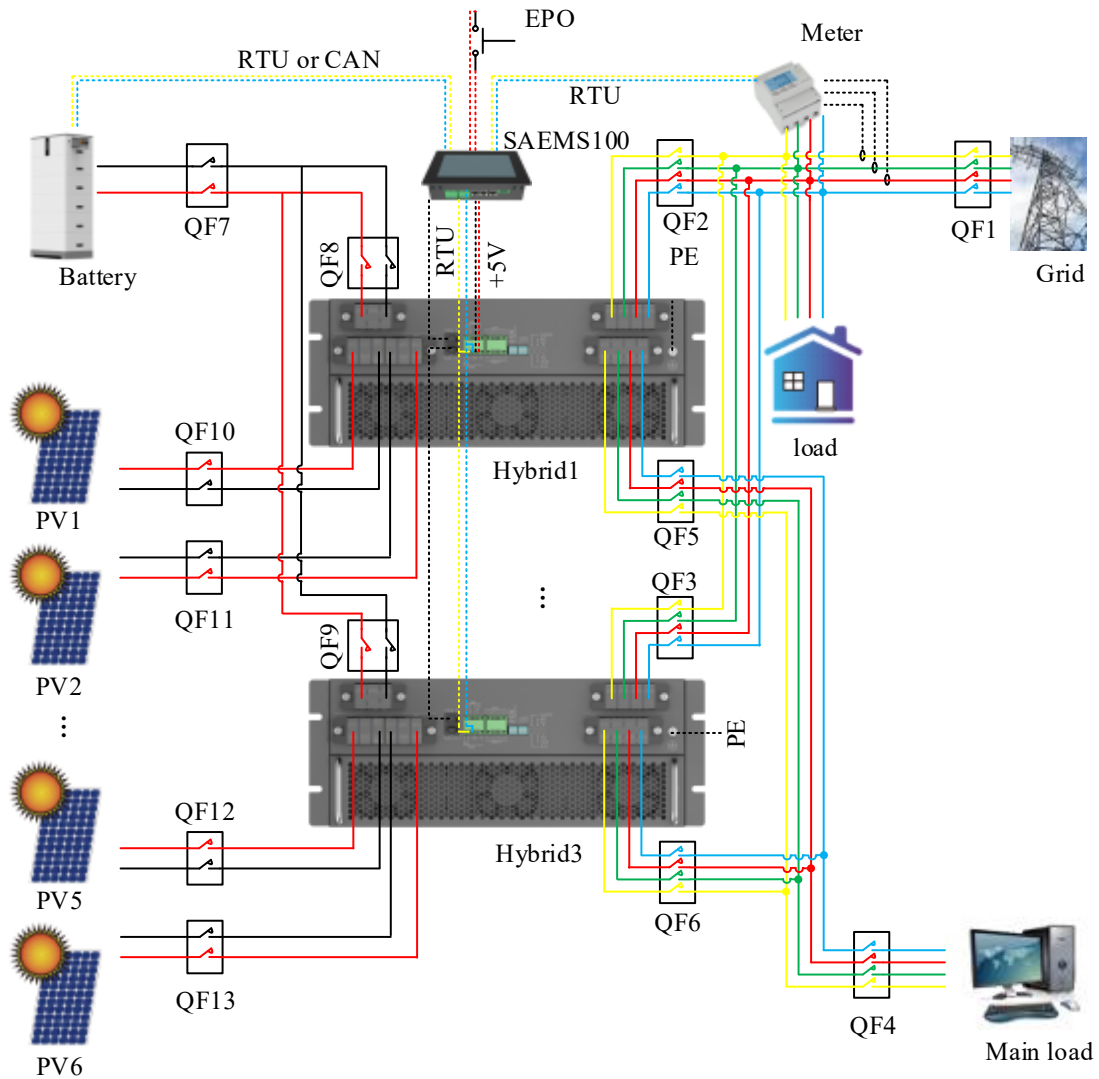

Figure 24 Schematic diagram of multi-unit parallel connection for single battery pack

Warning

- When using a photovoltaic simulator or DC power supply to replace solar panels for testing, first close the circuit breakers QF10, QF11, QF12, and QF13, then power on the simulator or DC power supply.
- For electricity meter selection, the Acrel ADL400 model is recommended.
- The CT of the electricity meter must be installed between the load and QF1; otherwise, the intended effect cannot be achieved.

- If the electricity meter is not installed, the inverter's internal anti-reverse flow function can be enabled. In this case, the load is powered by the grid, and the inverter only supplies power to critical loads.
- All inverters must be reliably grounded to prevent personal injury and equipment damage.

(2) Use cases with more than 3 parallel devices

The wiring diagram of this operational mode is shown in Figure 25. The parallel configuration requires an external STS device to enable grid-connection/disconnection switching, with a maximum capacity of 15 parallel units. All power cables connected to the converter must be equipped with external disconnect switches. The SAEMS200 system performs coordinated control based on user-defined parameters, enabling customized operation to meet diverse user requirements.

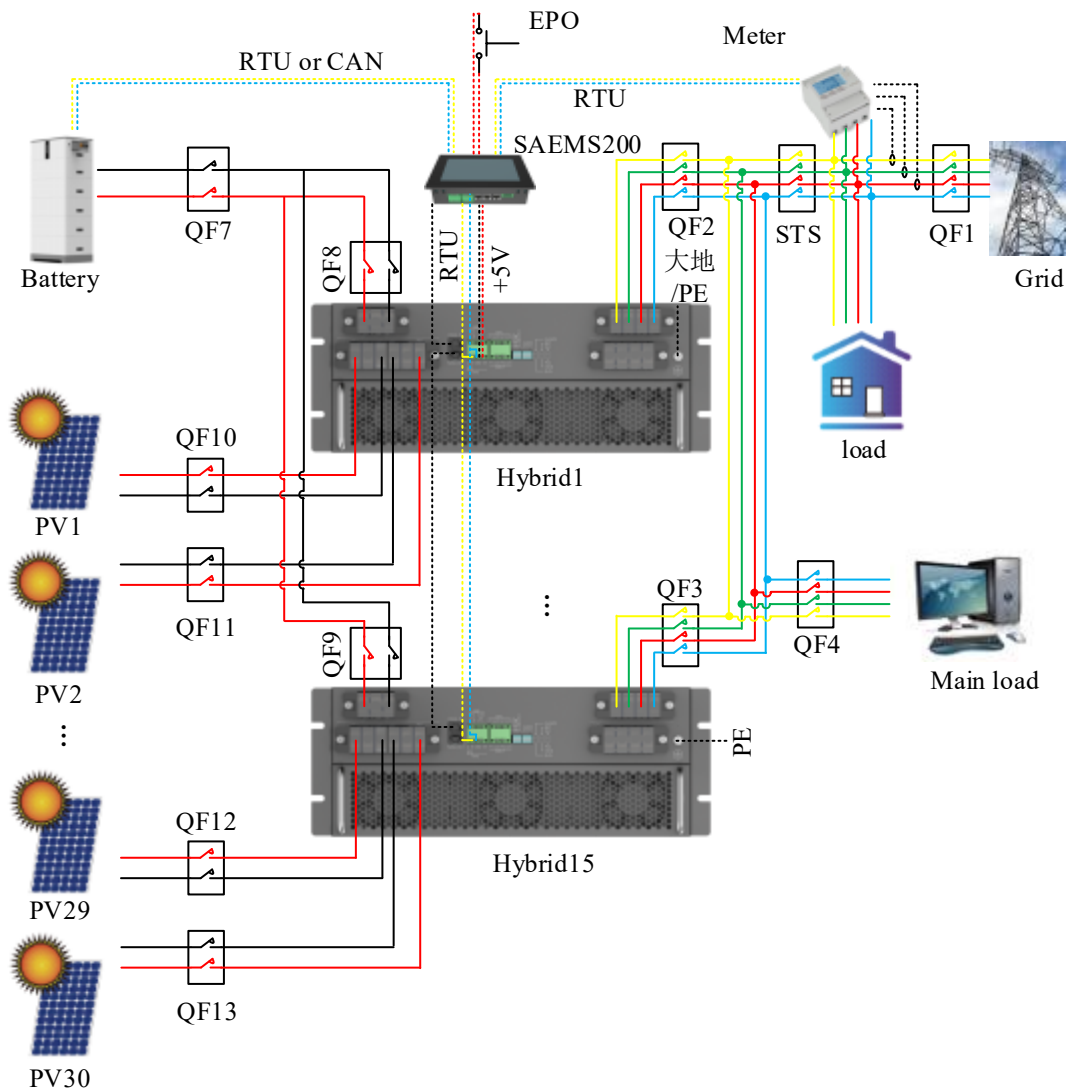

Figure 25 Schematic diagram of multi-unit parallel connection for single battery pack



- When using a photovoltaic simulator or DC power supply to replace solar panels for

testing, first close the circuit breakers QF10, QF11, QF12, and QF13, then power on the simulator or DC power supply.

- For electricity meter selection, the Acrel ADL400 model is recommended.
- The CT must be installed between the load and QF1; otherwise, the intended effect cannot be achieved.
- If no electricity meter is installed, enable the STS's internal anti-reverse flow function. In this case, the load is powered by the grid, and the converter only supplies power to critical loads.
- All converters and STS must be reliably grounded to prevent personal injury and equipment damage.

6 Operation of Up and Down Power and Fault

Diagnosis

6.1 Power on/off operation

6.1.1 Power-up procedure after initial power-up and maintenance

(1) Off-grid operation with photovoltaic power generation

Step 1: Verify that the power and communication cables are properly and securely connected, the module address is correct, and the communication matching resistor is properly enabled. Refer to the wiring diagram in Section 5.5 for inspection.

Step 2: Use the multimeter's buzzer function to test for short circuits between the battery port's positive/negative terminals, PV1 port's positive/negative terminals, PV2 port's positive/negative terminals, and the load port's L1, L2, L3, and N terminals. If the multimeter's buzzer sounds and the displayed impedance is less than 2Ω , a short circuit exists between the tested terminals. Check the corresponding power cable for insulation damage or incorrect wiring. Otherwise, no short circuit is detected.

Step 3: Use the multimeter's buzzer function to test for short circuits between the battery port's positive/negative terminals, the load port's L1, L2, L3, and N terminals, and the positive/negative terminals of PV1 and PV2 relative to PE (grounding terminal). If the multimeter's buzzer sounds and the displayed impedance is below 2Ω , the tested port is short-

circuited to ground. Check the corresponding power cable for insulation damage or incorrect wiring. Otherwise, no short circuit is detected.

Step 4: Use the DC voltage setting on a multimeter to test the battery voltage. Verify if it falls within the converter's required voltage range. If not, replace the battery pack to ensure the voltage meets the converter's specifications.

Step 5: Close the circuit breaker at the converter's battery terminal and wait for 10 seconds. Check if the fault indicator and battery status indicator on the front panel remain illuminated. If neither light up, use a multimeter to verify the voltage at the battery terminal falls within the converter's required voltage range. If not, inspect the power cables for correct connections and check for any reverse wiring at the battery terminal. If no reverse wiring is detected and the voltage is within the required range, contact the converter's maintenance team for troubleshooting. (If the converter is in parallel operation, close the circuit breaker connected to the converter's load terminal and disconnect the main circuit breaker linked to critical loads.)

Step 6: Wait for the converter fault indicator light to transition from on to off and the status indicator light to flash at a rate of once per second. Then, issue the inverter startup command. After 20 seconds, check if the status indicator light transitions from flashing to steady-state. If the status indicator light does not turn steady-state, verify whether the startup command was successfully issued and if the communication protocol is compatible.

Step 7: Use the AC voltage test setting on the multimeter to measure the RMS voltage between the converter's load terminals (L1, L2, L3) and the neutral (N). Verify if the measured value is within the $230 \pm 2V$ range. If the measured value deviates from this range, confirm the multimeter's setting matches the AC voltage test requirements. If the multimeter's setting is within the AC voltage test range but the measured value still exceeds or falls below this threshold, contact the converter's technical support for troubleshooting.

Step 8: Close the main circuit breaker on the critical load side and verify if the critical load operates normally. If the critical load functions properly, the converter is successfully powered on. If the critical load fails to operate normally, use the AC voltage test function of a multimeter to check the AC voltage at the critical load. If abnormal AC voltage is detected at the critical load, inspect the voltage at the converter's output terminals. If the converter's AC output voltage is

normal, the cable connection between the converter and the critical load is likely faulty. If the converter's AC output voltage is abnormal, contact the converter's technical support team immediately for troubleshooting.

Step 9: Use the DC voltage setting of a multimeter to test the photovoltaic voltage. Check if it falls within the converter's required voltage range. If the voltage exceeds this range (especially under favorable sunlight conditions), reduce the number of connected PV modules to bring it within the required range. If the voltage is below the range, increase the number of connected PV modules to meet the converter's requirements.

Step 10: After closing the circuit breaker at the converter's photovoltaic (PV) terminal and waiting 10 seconds, check if the PV status indicator light on the front panel flashes. If the light does not flash, use a multimeter in DC voltage mode to measure the PV terminal voltage. Verify if it falls within the converter's specified PV voltage range. If not, inspect the power cables for correct connections and check for any reverse wiring in the PV terminal cables. If no reverse wiring is found and the PV terminal voltage meets the specified range, contact the converter's maintenance team for further assistance.

Step 11: Send the converter's PV startup command. After 20 seconds, the PV status indicator light should switch from flashing at 1-second intervals to staying on. If the light fails to stay on, verify the command's successful transmission and communication protocol compatibility (configurable to automatically activate PV upon meeting startup conditions).

(1) Grid-connected photovoltaic system with on-grid operation

Step 1: Verify that the power and communication cables are properly and securely connected, the module address is correct, and the communication matching resistor is properly enabled. Refer to the wiring diagram in Section 5.5 for inspection.

Step 2: Use the multimeter's buzzer function to test for short circuits between: (1) positive and negative terminals of the battery port; (2) positive and negative terminals of PV1 port; (3) positive and negative terminals of PV2 port; (4) L1, L2, L3 and N terminals of the load port; (5) L1, L2, L3 and N terminals of the grid port. If the multimeter buzzer sounds and the displayed impedance is below 2Ω , a short circuit exists between the tested terminals. Inspect the power cable for insulation damage or incorrect wiring. If no abnormalities are found,

contact the converter maintenance team for resolution. Otherwise, no short circuit is detected.

Step 3: Use the multimeter's buzzer function to test for short circuits between the battery port's positive/negative terminals, load port's L1, L2, L3, and N terminals, PV1's positive/negative terminals, PV2's positive/negative terminals, and grid port's L1, L2, L3, N terminals, and PE (grounding terminal). If the multimeter's buzzer sounds and the displayed impedance is less than 2Ω , the tested port is short-circuited to ground. Check the corresponding power cable for insulation damage or incorrect wiring. Otherwise, no short circuit exists.

Step 4: Use the DC voltage setting on a multimeter to test the battery voltage. Verify if it falls within the converter's required voltage range. If not, replace the battery pack to ensure the voltage meets the converter's specifications.

Step 5: Use the AC voltage setting on a multimeter to test the grid voltage. Verify if the phase voltage falls within the converter's required range. If not, check the phase sequence and cable connections. If both are correct, the converter will operate in off-grid mode. Once grid voltage stabilizes, it will automatically reconnect to the grid.

Step 6: Close the circuit breaker at the converter battery terminal and wait for 10 seconds. Check if the fault indicator and battery status indicator on the front panel remain illuminated. If neither light up, use the DC measurement function of a multimeter to verify whether the voltage at the converter battery terminal falls within the required range. If not, inspect the power cables for correct connections and check for any reverse wiring at the battery terminal. If no reverse wiring is detected and the voltage is within the required range, contact the converter maintenance team for further action. (If the converter is in parallel operation, close the circuit breaker connected to the converter's load terminal and disconnect the main circuit breaker linked to critical loads.)

Step 7: Close the circuit breaker at the converter's grid terminal and wait for 10 seconds. Check if the grid status indicator light on the front panel flashes. If it does not, use the AC test function of a multimeter to verify whether the voltage at the grid terminal falls within the converter's required voltage range. If not, confirm whether the power cables are properly connected and if there is any phase sequence error in the grid terminal cable. If no reverse connection is detected, the grid is faulty. Wait until the grid normalizes, then recheck the converter's status. If the

voltage at the grid terminal is within the required range, contact the converter's maintenance team for troubleshooting.

Step 8: Wait until the converter fault indicator light turns from on to off and the status indicator light flashes at a rate of once per second. Then, issue the inverter startup command. After 20 seconds, the converter operation status indicator light, battery status indicator light, and grid status indicator light should transition from flashing to steady-state at a rate of once per second. If the operation status indicator light and battery status indicator light fail to stabilize, verify whether the startup command was successfully issued and if the communication protocol is compatible. If the grid status indicator light does not transition from flashing to steady-state, contact the converter maintenance team for troubleshooting.

Step 9: Use the AC voltage test setting on the multimeter to measure the RMS voltage difference between the converter's load terminals (L1, L2, L3) and the neutral (N) relative to the grid phase voltage. Ensure the difference exceeds 2V. If the measured RMS voltage difference is higher than this threshold, verify that the multimeter's setting matches the AC voltage test requirements. If the multimeter's setting is within the AC voltage test range, confirm the measured RMS voltage difference still exceeds 2V. In this case, contact the converter's technical support for troubleshooting.

Step 10: Close the main circuit breaker on the critical load side and verify if the critical load operates normally. If the critical load functions properly, the converter is operational. If the critical load fails to operate normally, use the AC voltage test function of a multimeter to check the AC voltage at the critical load. If the AC voltage at the critical load is abnormal, the cable connection between the converter and the critical load is faulty. If the AC voltage at the critical load is normal, the critical load is damaged.

Step 11: Measure the PV voltage using the DC voltage setting of a multimeter to verify if it falls within the converter's specified range. If the PV voltage exceeds the required range, reduce the number of PV modules connected in series to bring it within the specified range. If the PV voltage is below the required range (under favorable lighting conditions), increase the number of PV modules connected in series to ensure the PV voltage remains within the specified range.

Step 12: After closing the circuit breaker at the converter's photovoltaic (PV) terminal and waiting 10 seconds, check if the PV status indicator light on the front panel flashes. If the light does

not flash, use a multimeter in DC voltage mode to measure the PV terminal voltage. Verify if it falls within the converter's specified PV voltage range. If not, inspect the power cables for correct connections and check for any reverse wiring in the PV terminal cables. If no reverse wiring is detected and the PV terminal voltage is within the specified range, contact the converter's maintenance team for further assistance.

Step 13: Send the converter's PV startup command. After a 20-second delay, the PV status indicator light should transition from a 1-second-on-off pattern to a continuous on state. If the light fails to turn on, verify the command's successful transmission and communication protocol compatibility (configurable to trigger automatic startup upon PV conditions being met).

(2) Grid-connected operation without PV startup

Step 1: Verify that the power and communication cables are properly and securely connected, the module address is correct, and the communication matching resistor is properly enabled. Refer to the wiring diagram in Section 5.5 for inspection.

Step 2: Use the multimeter's buzzer function to test for short circuits between: (1) positive and negative terminals of the battery port; (2) positive and negative terminals of PV1 port; (3) positive and negative terminals of PV2 port; (4) L1, L2, L3 and N terminals of the load port; (5) L1, L2, L3 and N terminals of the grid port. If the multimeter buzzer sounds and the displayed impedance is below 2Ω , a short circuit exists between the tested terminals. Inspect the power cable for insulation damage or incorrect wiring. If no abnormalities are found, contact the converter maintenance team for resolution. Otherwise, no short circuit is detected.

Step 3: Use the multimeter's buzzer function to test for short circuits between the battery port's positive/negative terminals, load port's L1, L2, L3, and N terminals, PV1's positive/negative terminals, PV2's positive/negative terminals, and grid port's L1, L2, L3, N terminals, and PE (grounding terminal). If the multimeter's buzzer sounds and the displayed impedance is less than 2Ω , the tested port is short-circuited to ground. Check the corresponding power cable for insulation damage or incorrect wiring. Otherwise, no short circuit exists.

Step 4: Use the DC voltage setting on a multimeter to test the battery voltage. Verify if it falls within the converter's required voltage range. If not, replace the battery pack to ensure the voltage meets the converter's specifications.

Step 5: Use the AC voltage setting on a multimeter to test the grid voltage. Verify if the phase voltage falls within the converter's required range. If not, check the phase sequence and cable connections. If both are correct, the converter will operate in off-grid mode. Once grid voltage stabilizes, it will automatically reconnect to the grid.

Step 6: Close the circuit breaker at the converter battery terminal and wait for 10 seconds. Check if the fault indicator and battery status indicator on the front panel remain illuminated. If neither light up, use the DC measurement function of a multimeter to verify whether the voltage at the converter battery terminal falls within the required range. If not, inspect the power cables for correct connections and check for any reverse wiring at the battery terminal. If no reverse wiring is detected and the voltage is within the required range, contact the converter maintenance team for further action. (If the converter is in parallel operation, close the circuit breaker connected to the converter's load terminal and disconnect the main circuit breaker linked to critical loads.)

Step 7: Close the circuit breaker at the converter's grid terminal and wait for 10 seconds. Check if the grid status indicator light on the front panel flashes. If it does not, use the AC test function of a multimeter to verify whether the voltage at the grid terminal falls within the converter's required voltage range. If not, confirm whether the power cables are properly connected and if there is any phase sequence error in the grid terminal cable. If no reverse connection is detected, the grid is faulty. Wait until the grid normalizes, then recheck the converter's status. If the voltage at the grid terminal is within the required range, contact the converter's maintenance team for troubleshooting.

Step 8: Wait until the converter fault indicator light turns from on to off and the status indicator light flashes at a rate of once per second. Then, issue the inverter startup command. After 20 seconds, the converter operation status indicator light, battery status indicator light, and grid status indicator light should transition from flashing to steady-state at a rate of once per second. If the operation status indicator light and battery status indicator light fail to stabilize, verify whether the startup command was successfully issued and if the communication protocol is compatible. If the grid status indicator light does not transition from flashing to steady-state, contact the converter maintenance team for troubleshooting.

Step 9: Use the AC voltage test setting on the multimeter to measure the RMS voltage difference

between the converter's load terminals (L1, L2, L3) and the neutral (N) relative to the grid phase voltage. Ensure the difference exceeds 2V. If the measured RMS voltage difference is higher than this threshold, verify that the multimeter's setting matches the AC voltage test requirements. If the multimeter's setting is within the AC voltage test range, confirm the measured RMS voltage difference still exceeds 2V. In this case, contact the converter's technical support for troubleshooting.

Step 10: Close the main circuit breaker on the critical load side and verify if the critical load operates normally. If the critical load functions properly, the converter is operational. If the critical load fails to operate normally, use the AC voltage test function of a multimeter to check the AC voltage at the critical load. If the AC voltage at the critical load is abnormal, the cable connection between the converter and the critical load is faulty. If the AC voltage at the critical load is normal, the critical load is damaged.

6.1.2 Preparation for the lower power step

(1) Grid-connected photovoltaic system

Step 1: Issue the shutdown command and monitor the operation status indicators on the converter's front panel, including the grid status indicator, battery status indicator, PV1 status indicator, and PV2 status indicator. Check if these indicators are flashing at 1-second intervals or remain constantly off. If any of the operation status indicators, grid status indicator, battery status indicator, or PV status indicators are persistently lit, verify whether there are communication protocol issues with the converter or if the shutdown command was successfully issued. If no issues are detected, contact the converter's technical team for troubleshooting.

Step 2: Ensure critical loads are powered off or the external maintenance bypass switch is closed. Otherwise, servicing the converter may cut off power to critical loads, causing unnecessary losses.

Step 3: Disconnect the grid port, load port, battery port, PV1 port, and PV2 port circuit breakers of the converter, then install a "Under Maintenance, Power Off" warning sign at the circuit breaker. At this stage, the converter's fault indicator light will remain on, while the grid status, PV status, and battery status indicators will turn off.

Step 4: Use the DC and AC voltage test functions of the multimeter to measure the voltage between

each of the following ports and the PE: PV1, PV2, battery, grid, and load. Verify if the voltage drops below 60V. If the voltage remains above 60V, wait until it decreases to 60V or below before proceeding.

Step 5: Use the DC and AC voltage test functions of the multimeter to measure the voltage between the positive and negative terminals of PV1, PV2, and battery ports; between grid ports L1, L2, and L3; between grid ports L1, L2, L3 and N; between load ports L1, L2, L3 and N; and between load ports L1, L2, L3 and N. Check if the voltage drops below 60V. If the voltage remains above 60V, wait until it drops below 60V before proceeding.

Step 6: Wait 15 minutes for the converter to fully discharge.

Step 7: Take photos with your phone to document cable connections, preventing wiring errors after maintenance.

Step 8: Disconnect the power and communication cables connected to the converter, then insulate them with tape.

Step 9: The converter must be removed by two or more personnel for maintenance and repair. It is strictly prohibited for a single person to perform such operations.

(2) Grid-connected shutdown without PV

Step 1: Send the shutdown command and monitor the operation status indicators on the converter's front panel—specifically the power grid status indicator and battery status indicator—to verify whether they are flashing at 1Hz or remain off. If any of these indicators stay on, check the communication protocol with the converter and confirm the shutdown command was successfully sent. If no issues are detected, contact the converter's technical team for troubleshooting.

Step 2: Ensure critical loads are powered off or the external maintenance bypass switch is closed. Otherwise, servicing the converter may cut off power to critical loads, causing unnecessary losses.

Step 3: Disconnect the grid port, load port, and battery port circuit breakers of the converter, then install a "Under Maintenance, Do Not Power On" sign at the circuit breaker. At this point, the converter's fault indicator light will remain on, while the grid status indicator light and battery status indicator light will be off.

Step 4: Use the DC and AC voltage test ranges of the multimeter to measure the voltage between the battery port, power grid port, load port, and PE. Check if the voltage drops below 60V. If it remains above 60V, wait until all port voltages are below 60V before proceeding.

Step 5: Use the multimeter's DC and AC voltage test settings to measure the voltage between the battery terminals (positive/negative), the grid ports (L1, L2, L3), the grid ports (L1, L2, L3 and N), and the load ports (L1, L2, L3 and N). Check if the voltage drops below 60V. If the voltage remains above 60V, wait until it drops below 60V before proceeding.

Step 6: Wait 15 minutes for the converter to fully discharge.

Step 7: Take photos with your phone to document cable connections, preventing wiring errors after maintenance.

Step 8: Disconnect the power and communication cables connected to the converter, then insulate them with tape.

Step 9: The converter must be removed by two or more personnel for maintenance and repair. It is strictly prohibited for a single person to perform such operations.

(3) off-grid photovoltaic shutdown

Step 1: Ensure critical loads are powered off, as maintaining the converter may cause them to lose power and result in unnecessary losses.

Step 2: Send the shutdown command and monitor whether the operation status indicator and battery status indicator on the converter's front panel are flashing every second or remain off. If either light stays on, verify the communication protocol with the converter and confirm the shutdown command was successfully sent. If no issues are found, contact the converter's technical team for troubleshooting.

Step 3: Disconnect the load-side and battery-side circuit breakers of the converter, then install a 'Maintenance in Progress-Do Not Power On' sign at the circuit breaker. The converter's fault indicator light will remain on, while the battery status indicator light will stay off.

Step 4: Use the DC and AC voltage test ranges of the multimeter to measure the voltage between the battery port, load port, and PE. Check if the voltage drops below 60V. If it remains above 60V, wait until all port voltages drop below 60V before proceeding.

Step 5: Use the multimeter's DC and AC voltage test settings to measure the voltage between the

battery terminals (positive/negative), load ports L1, L2, and L3, and load ports L1, L2, L3 and N. Check if the voltage drops below 60V. If the voltage remains above 60V, wait until all port voltages are below 60V before proceeding.

Step 6: Wait 15 minutes for the converter to fully discharge.

Step 7: Take photos with your phone to document cable connections, preventing wiring errors after maintenance.

Step 8: Disconnect the power and communication cables connected to the converter, then insulate them with tape.

Step 9: The converter must be removed by two or more personnel for maintenance and repair. It is strictly prohibited for a single person to perform such operations.

6.1.3 boot up by host computer control

As shown in Figure 26, when the converter fault indicator remains off and the operational status indicator with battery status indicator flash at a 1-second interval, the host control software selects the module ID in the upper-left corner. This ID must match the address dial code on the module; otherwise, the converter cannot be configured or operated. After selecting the correct module ID, click the All Start button in the lower-left corner of the host control software to initiate operation. For parallel-connected converters, enable Multi-Unit Mode to control all units simultaneously. Individual modules can be controlled by selecting their respective IDs.



Figure 26 Schematic diagram of power-on/off settings

As shown in Figure 27, the converter's operational status can be monitored via the 'Operating Mode' field in the basic information panel at the top-left corner of the host computer software. When the converter is in grid-connected operation, users can configure charge/discharge power by clicking 'Grid-connected Power Dispatch Mode' with the left mouse button, where positive values indicate discharge power and negative values indicate charge power.

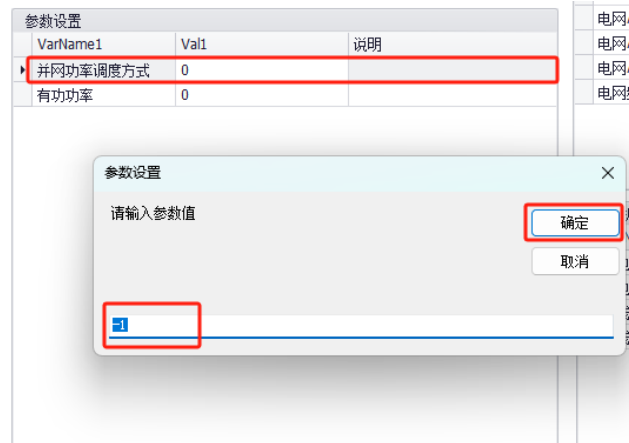

Figure 27 Power Scheduling Window

6.1.4 Customer EMS Control Operation and Power On/Off

The converter is controlled by the parameters such as the on/off command, charging power, discharging power, maximum allowable charging current and maximum allowable discharging current of the battery, which can be found in the relevant communication protocol.

6.1.5 Equipped with SAEMS100/SAEMS200 for control operation and power switching

The converter can be controlled via physical power buttons or screen settings. Users can customize parameters to meet their specific charging and discharging needs at different times. For detailed configuration, refer to the user manual of SAEMS series products.

6.1.6 Contains information for setting up Generation Limit and ExportLimit Control

The product we are using is PCM170 from our company. It has an inductor sensor that detects the current flowing from the inverter to the power grid, preventing the reverse flow of current to the power grid. The specific operation of PCM is as follows: 1. Send the 06 message via the Modbus485 protocol to address 871 = 1 (to activate the function). 2. Write the power value to address 353. The inverter will follow this power value. If the power exceeds this limit, the PCM will automatically reduce the output power of the inverter to ensure that the actual power does not exceed the set value.

6.2 fault diagnosis and solution

6.2.1 Module Alarm or Failure and Solutions

Alarm or fault name	fault code	Shut down	fault recovery mode	Troubleshooting measures
---------------------	------------	-----------	---------------------	--------------------------

Soft launch failed	1	shut down	self-recovery	<ol style="list-style-type: none"> 1. Power off the module, wait 1-2 minutes, then restart it. 2. If the issue persists after the above steps, please contact Zhongteng Micro Network customer service for assistance.
Duplicate address or invalid address	3	shut down	Check before startup and restore after power loss	<ol style="list-style-type: none"> 1. Power off the module and reselect a module address that differs from the system's default, with addresses ranging from #1 to #10. 2. The address range is #1 to #10. The dial switch is arranged from left to right, with the left side representing the high bit and the right side the low bit. The dial switch must be set to the "NO" position to be valid, and the calculation is performed in binary. 3. The address will take effect after power-off and reboot.
ECAP hitch	4	shut down	self-recovery	<ol style="list-style-type: none"> 1. Check if the network cable between the parallel machines is properly connected, and reconnect it. 2. Replace the network cable.
AC relay short circuit	5	shut down	downlink recovery	<ol style="list-style-type: none"> 1. Power off the module and check if the inverter's intermediate relay is damaged.
CPLD wave-by-wave current limiting fault	6	shut down	self-recovery	<ol style="list-style-type: none"> 1. The machine has experienced overcurrent. Check the load or wiring.
short circuit between output lines	8	shut down	self-recovery	<ol style="list-style-type: none"> 1. Power off the module and check for any short circuits between phases and lines.
overload protection shutdown	9	shut down	self-recovery	<ol style="list-style-type: none"> 1. The device has been overloaded for an extended period. Check the load.

6.2.2 Battery Failure and Solutions

Alarm or fault name	fault code	Shut down	fault recovery mode	Troubleshooting measures
---------------------	------------	-----------	---------------------	--------------------------

bus unbalance	17	shut down	self-recovery	<ol style="list-style-type: none"> 1. Power off the module, wait 1-2 minutes, then restart it. 2. Contact customer service for assistance.
bus overvoltage	18	shut down	self-recovery	<ol style="list-style-type: none"> 1. Check for overvoltage on the P/N terminals of the busbar. Power off, wait for 1 minute, then power on again.
bus under-voltage	19	shut down	self-recovery	<ol style="list-style-type: none"> 1. Check if the P and N terminals of the busbar are under-voltage and if the input voltage is too low; 2. Contact customer service for assistance.
bus sampling error	20	shut down	self-recovery	<ol style="list-style-type: none"> 1. The bus voltage is not equal to P+N due to sampling errors.
DC soft start failed	21	shut down	self-recovery	<ol style="list-style-type: none"> 1. Wait for the bus voltage to rise before restarting the system
battery reverse	22	shut down	self-recovery	<ol style="list-style-type: none"> 1. Check if the battery's positive and negative terminals are connected in reverse.
battery overvoltage	23	shut down	self-recovery	<ol style="list-style-type: none"> 1. Check if the battery input is overvoltage. Power off, wait for 1 minute, then power on again.
battery under-voltage	24	shut down	self-recovery	<ol style="list-style-type: none"> 1. Check if the battery input voltage is low.
overcurrent discharge	25	shut down	self-recovery	<ol style="list-style-type: none"> 1. Check for overcurrent during discharge.
overcharge current	26	shut down	self-recovery	<ol style="list-style-type: none"> 1. Check for overcurrent during charging.
DC contactor fault	32	shut down	self-recovery	<ol style="list-style-type: none"> 1. PTC malfunction or DC contactor malfunction.

6.2.3 Power Grid Failure and Solutions

Alarm or fault name	fault code	Shut down	fault recovery mode	Troubleshooting measures
The power grid frequency is low.	33	shut down	self-recovery	<ol style="list-style-type: none"> 1. Check whether the low-frequency protection setting of the power grid is set too high; 2. Verify if the time setting for the grid's low-frequency protection point is too short; 3. Check if the actual grid frequency is too low.

high power frequency	34	shut down	self-recovery	<ol style="list-style-type: none"> 1. Check whether the high-frequency protection setting of the power grid is too low; 2. Verify if the time setting for the power grid's high-frequency protection point is too short; 3. Check if the actual grid frequency is too high.
Low grid voltage	35	shut down	self-recovery	<ol style="list-style-type: none"> 1. Check whether the setting of the grid under-voltage protection point is too high; 2. Check if the time setting for the grid under-voltage protection point is too short; 3. Check if the actual voltage of the power grid is too low.
high grid voltage	36	shut down	self-recovery	<ol style="list-style-type: none"> 1. Check whether the overvoltage protection setting of the power grid is too low; 2. Check if the time setting for the grid overvoltage protection point is too short; 3. Check if the actual voltage of the power grid is too high.
phase sequence inversion	37	shut down	self-recovery	<ol style="list-style-type: none"> 1. Check for reverse phase sequence.
isolated island fault	40	shut down	self-recovery	
Abnormal output current	41	shut down	self-recovery	<ol style="list-style-type: none"> 1. Check if the current output is overcurrent; 2. Check for short circuits in the AC output.
Abnormal inverter overcurrent	43	Do not turn off	Alert, restored	The inductance current of the machine is not consistent with the output current.
abnormal leakage current	47	Do not turn off	Alert, restored	<ol style="list-style-type: none"> 1. Check if the leakage current protection threshold is set too low; 2. Check if the leakage current protection time is too short; 3. Inspect the power circuit for insulation issues (requires power-off inspection).

6.2.4 System Faults and Solutions of Module

Alarm or fault name	fault code	Shut down	fault recovery mode	Troubleshooting measures
Fan malfunction	50	Do not turn off	Alert, restored	1. Check if the fan is damaged.
Mode error	52	shut down	self-recovery	1. Phase-locking failure in VF mode.
paragenic anomaly	53	shut down	self-recovery	1. Check if the auxiliary power supply voltage is too low.
SysFault	54	shut down	self-recovery	1. Report other faults that caused the shutdown. To resolve this issue, first eliminate the other faults.
Arm hitch	55	shut down	self-recovery	1. Check for dialing errors, communication interruptions, or emergency stop malfunctions.
over temperature fault	57	shut down	self-recovery	1. Check whether the machine environment is too high and enhance ventilation.
IGBT temperature anomaly	58	shut down	self-recovery	1. Check if the temperature difference between the three IGBTs is excessive.
Flash initialization error	59	shut down	self-recovery	1.EEPROM chip initialization failed
Internal communication failure	61	shut down	self-recovery	1. Check for unstable or disconnected wiring between the DSP and ARM. 2. Does DSP or ARM lack programs?
CPLD unusual	64	shut down	self-recovery	1. The CPLD hardware version number is incorrect.

7 Installation and Use of Host Computer

7.1 Installation and Uninstallation of Host Computer

(1) Software installation

Step 1: Extract the installation package "setup.zip" to generate the executable file "setup.exe".

Step 2: Double-click the executable file "setup.exe" to install the software.

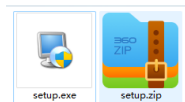

Figure 28

Step 3: As shown in Figures 29 and 30, follow the prompts to install. The installation path is a fixed default path and cannot be modified. (The installation path cannot contain Chinese characters or special symbols.)



Figure 29

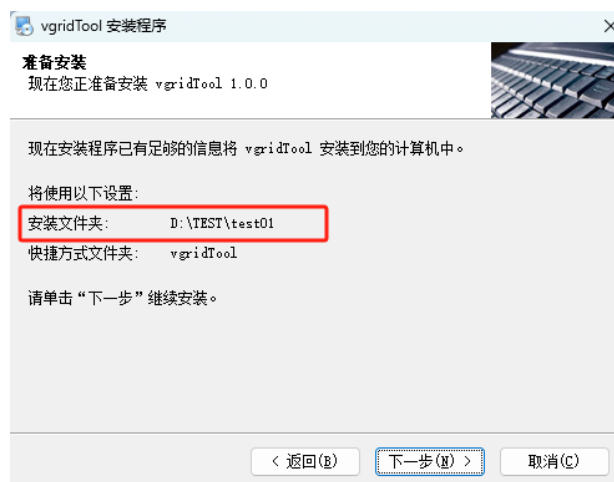

Figure 30

Step 4: After the software installation is successful, the desktop shortcut "VGrid" will be created, as

shown in Figure 31.



Figure 31

(2) Uninstall software

As shown in Figure 32, to uninstall the software, you need to go to the computer's settings and proceed with the uninstallation process.

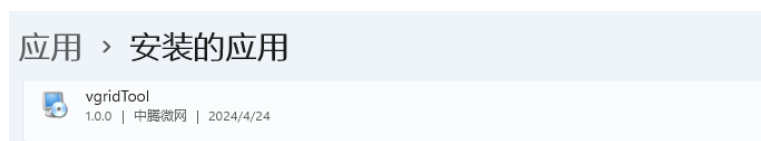

Figure 32: PC Unloading Window

7.2 Host computer usage

(1) communication junction

Connect the PC to the RTU communication port of the EMS.

(2) debugging function of host computer software

a) Communication connection page

Step 1: Select basic information. The user type is set to customer, with model and language options available.

Step 2: As shown in Figure 33, for RTU communication, the user must select the appropriate serial port and baud rate (default: 115200). After completing the parameter selection, click Connect.

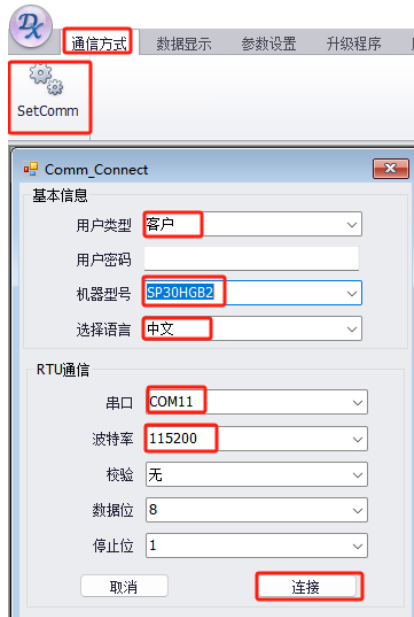

Figure 33

b) Display interface

The main information display interface is shown in Figure 34.

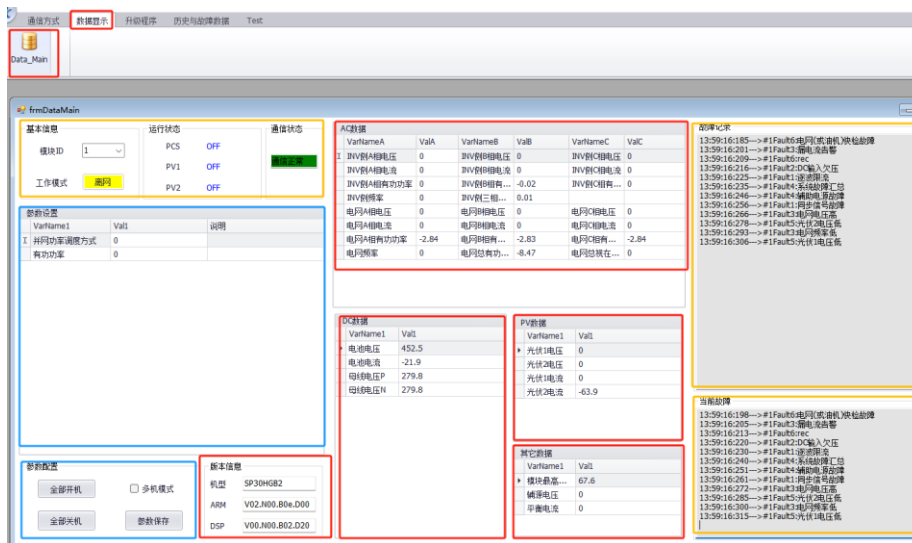

Figure 34 Information display interface

The data in red boxes are read-only attributes, including AC data, DC data, PV data, version information, and other information. Yellow boxes indicate status information, while blue boxes represent configurable data or information.

Status bar features (yellow box):

pay attention to

- To set basic information, select the target module's ID from the dropdown options.
- In the status bar, the device shows 'RUN' when operating normally and 'OFF' when

turned off.

- In the communication status box, the color is green when communication is normal, and red otherwise.
- The fault log box displays all faults (including historical and current ones). When a new fault occurs, the fault records accumulate. Double-click to select and clear the fault information.
- The fault box displays real-time updates of the displayed faults. When a fault changes, the information in the box will be updated. Double-click to clear the fault information.

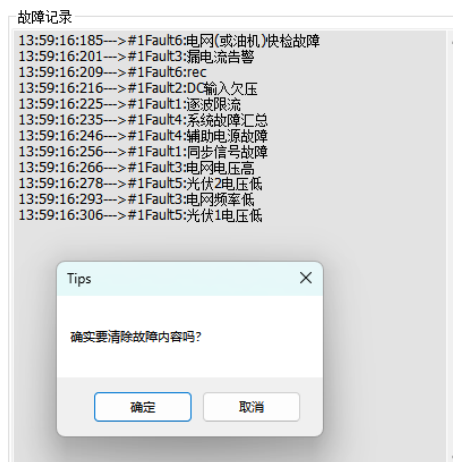

Figure 35

Data or information settings (in the blue box):

pay attention to

- Multi-device mode: If you select multi-device mode in the lower-left corner, all devices will be turned on or off. If you do not select multi-device mode, all devices will be turned on or off, but only the devices in the selected module will be affected.
- Parameter settings: Left-click any position in the parameter row to open a pop-up window for configuration.

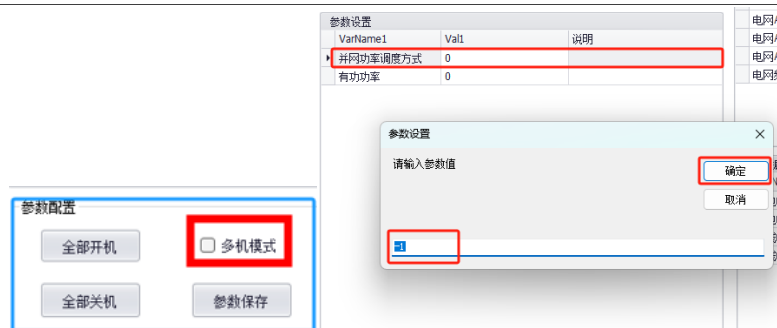

Figure 36

7.3 Host upgrade function

7.3.1 ARM native upgrade

The specific steps for upgrading your ARM device are shown in the figure.

Step 1: Close all information display and parameter setting interfaces;

Step 2: Select "Local ARM Upgrade";

Step 3: Select "ARM" from the dropdown menu.

Step 4: Select the modules to upgrade. You can upgrade a single module or upgrade multiple modules simultaneously.

Step 5: Select the files to upgrade. The upgrade path must exclude special characters like Chinese characters and parentheses, and the file name should use the device model as the prefix with an underscore as the separator, e.g., "SP30HGB2_master_CPU.hex".

Step 6: Click Start Upgrade. You can check the upgrade status through the upgrade process interface.

If the upgrade fails, follow the steps to identify the reason. If the upgrade is successful, the ARM upgrade is complete.

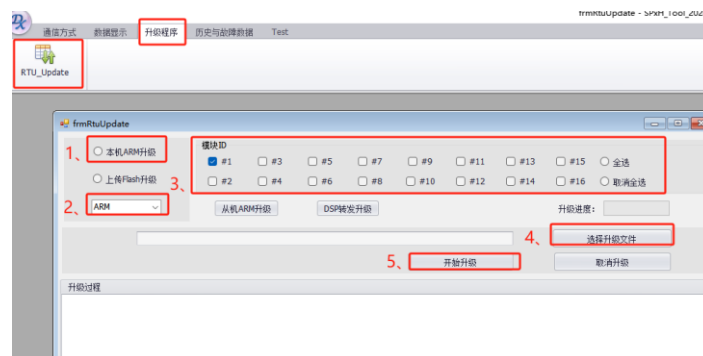

Figure 37

7.3.2 DSP local upgrade

pay attention to

- The DSP firmware upgrade consists of two phases: First, upload the update program to the ARM's Flash memory. Second, transfer the stored program to the DSP. During the upgrade, all other interfaces must be disabled to prevent failure. The upgrade file path must exclude Chinese characters and special symbols like parentheses, and the file name should use the device model as the prefix with an underscore as the separator, e.g., "SP30HGB2_0424.out".
- The first phase of local DSP upgrade follows these steps: First, select 'Upload Flash

Upgrade'; second, choose 'DSP' from the dropdown menu. After completing these four steps, click 'Start Upgrade'.

- After completing the first upgrade phase, proceed to the second upgrade phase. After selecting the first two steps, click "DSP Forward Upgrade" to start the second upgrade phase. You can check the upgrade progress through the progress bar (if the selection box is gray, this step will be skipped by default).

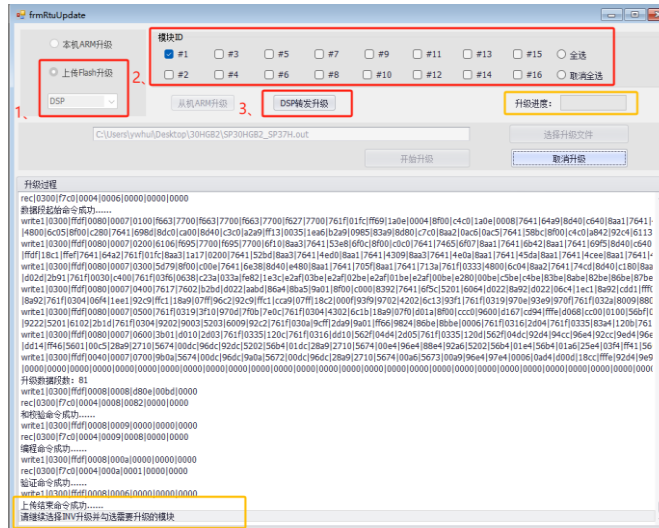

Figure 38

7.4 History and Faults

7.4.1 history

Select the module ID, click Query History, and click Export to Excel if needed to export the data.

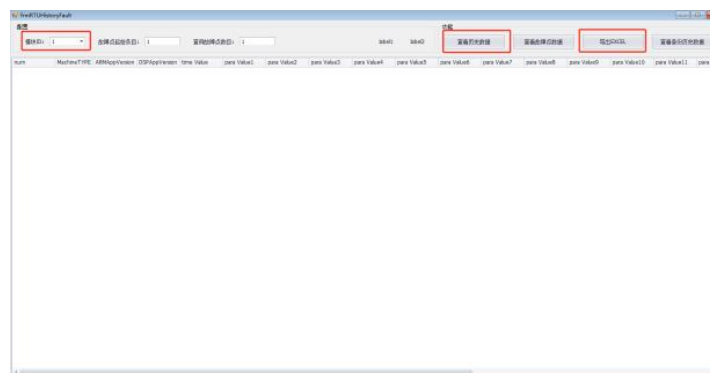

Figure 39

7.4.2 fault data

Select the module ID and the starting entry for fault points, which indicates the address offset for querying fault point data (default is 1, representing the latest fault record data). The number of

fault points is set to 1 by default (multiple queries are not supported). Click Query Fault Point Data, and if needed, click Export to Excel to export the data.

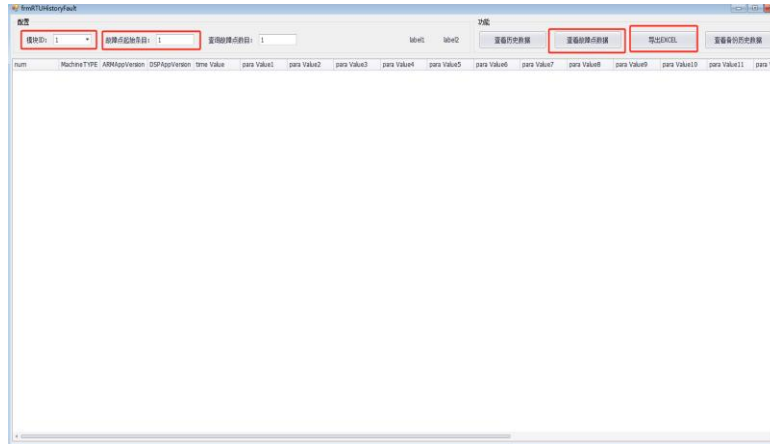

Figure 40

8 Other Notes

8.1 Temperature sensor interface

The SP30HBG2 ,SP25HBG2, SP30HBPS ,SP25HBPS Series does not include a connection terminal for a remote battery temperature sensor. If installing SP30HBG2,SP25HBG2, SP30HBPS ,SP25HBPS Series with leadacid batteries please check with Sinosoar for advice regarding charge settings

8.2 RCDs information

No external RCDs are required. The leakage current detection function is integrated inside the inverter. When the leakage current exceeds 300 mA, it will trigger an alarm and shut down the machine. The red light on the machine panel will illuminate.

8.3 Nameplate Description

The nameplate label in the test report is specifically for the Australian market.

8.4 Active anti-islanding method

Through the Modbus 485 protocol communication, by sending a 06 message to address 791

with a value of 1, the active island avoidance function can be enabled. Writing 0 will disable it.

8.5 Warranty Terms and Conditions

Our goods come with guarantees that cannot be excluded under the Australian Consumer Law. You are entitled to a replacement or refund for a major failure and compensation for any other reasonably foreseeable loss or damage. You are also entitled to have the goods repaired or replaced if the goods fail to be of acceptable quality and the failure does not amount to a major failure

8.6 Australia Region settings and modes response settings

The regional settings are sent via the Modbus485 protocol. The point number is 799. For Region A, it sends 1; for Region B, it sends 2; and for Region C, it sends 3. Different power responses are all placed in one setting point. By inputting different numbers, the inverter will automatically adjust the corresponding power response parameters. This point is sent via the Modbus 485 protocol and its address is 880.

880 Position data	Corresponding curve
8	UQ
9	UP
15	UPQ
16	UPQ-A
17	OFP
18	UFP

These two points are both readable and writable. To check the current value that has been sent out, you can use the 03 message of the Modbus 485 protocol to read the corresponding points.